

# Field Measurements and Proposed Analysis of Concrete Crosstie Bending Moments



Zhengboyang Gao, Henry Wolf, Riley  
Edwards, Marcus Dersch, and Yu Qian



AREMA 2016 Annual Conference & Exposition



# Outline

- Background and motivation
- FRA laboratory experimentation
- Field experimentation
- Ballast support back-calculator
- Conclusions
- Future work



# Project Background

- In 2013, UIUC conducted an international survey to determine most critical issues in concrete crosstie track
- Survey of railroads, concrete crosstie manufacturers, and researchers around the world
- Cracking from center binding (3<sup>rd</sup> most critical problem – International, 5<sup>th</sup> most critical – North America)
- Cracking from dynamic loads (4<sup>th</sup> most critical problem – International, 3<sup>rd</sup> most critical – North America)

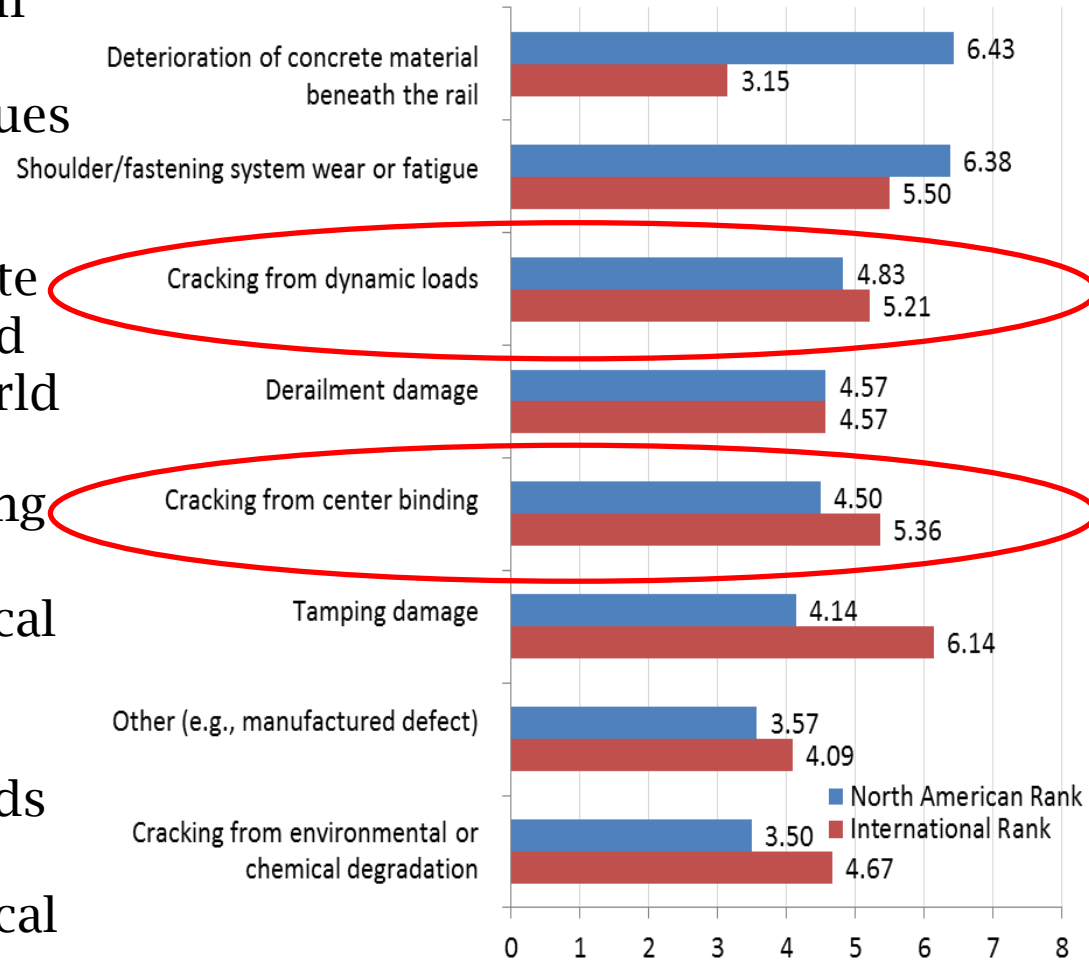

# Motivation for Research

- Previous analysis of FRA accident database indicated that deteriorated concrete crossties and support conditions are among the major track related accident causes in the US



Broken crosstie



Fouled ballast

- Industry partners stated that rail seat positive cracks are rarely seen in the field

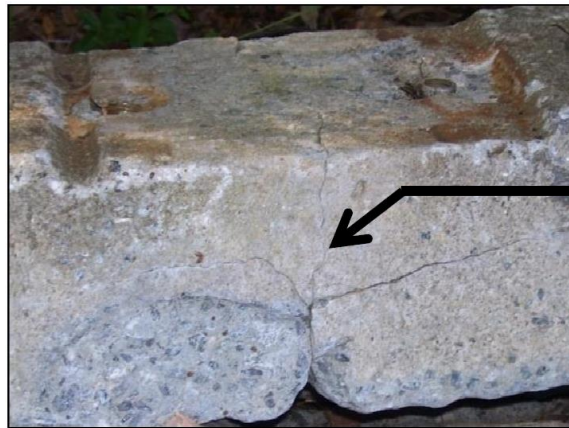

Rail seat positive crack



# Outline

- Background and motivation
- **FRA laboratory experimentation**
- Field experimentation
- Ballast support back-calculator
- Conclusions
- Future work



# Laboratory Experimentation

- Measure bending moments with different support conditions

- Support conditions

- Proper support
- Center binding
- Rail seat positive

- Cases were based on:

- Field conditions
- Expert opinion
- Industry partners feedback on draft experimental matrix

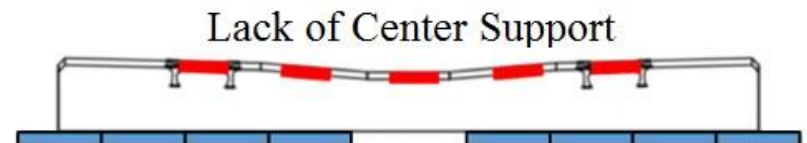
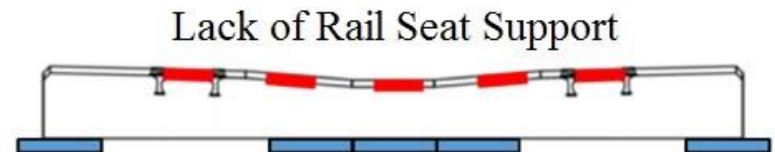
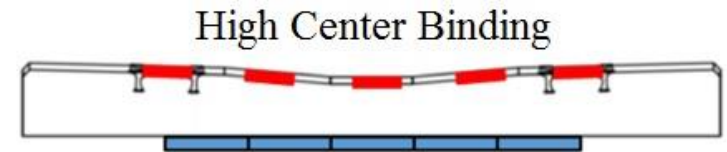
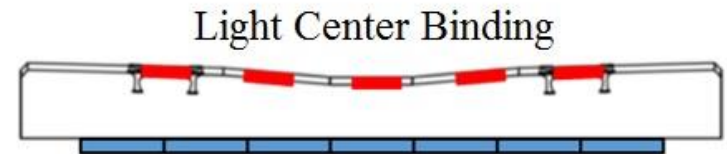
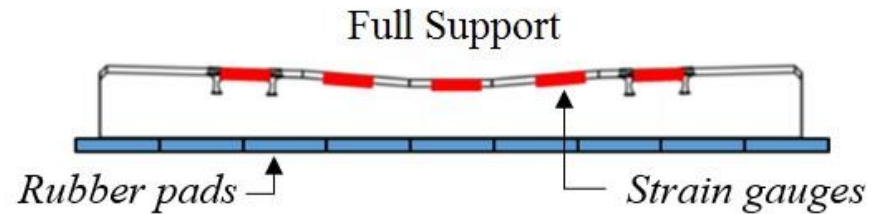

# Crosstie Instrumentation

- 5 surface strain gauges installed on each crosstie:
  - Rail seat gauges (to measure rail seat positive bending)
  - Center gauge (to measure center negative bending)
  - Intermediate gauge (to measure asymmetric loading or support)

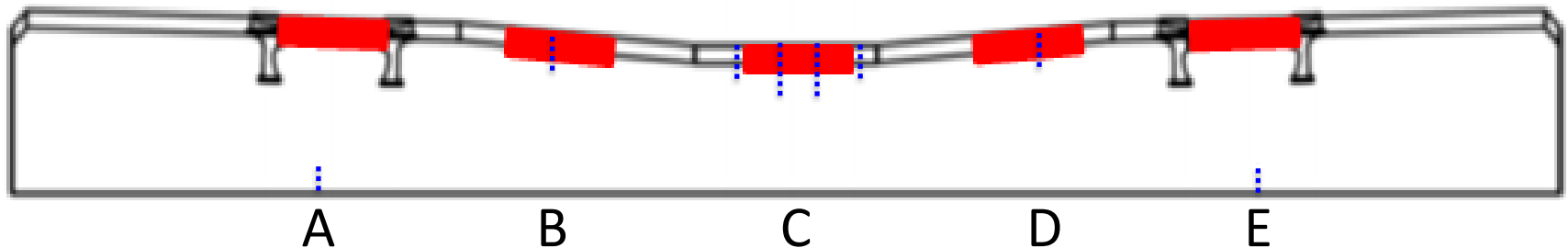
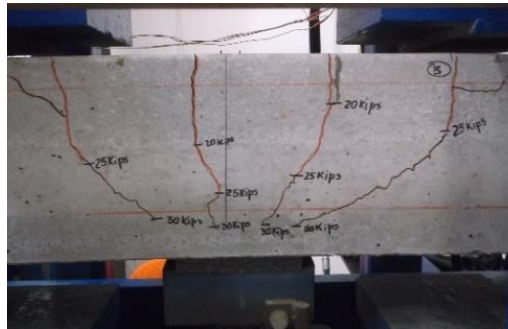
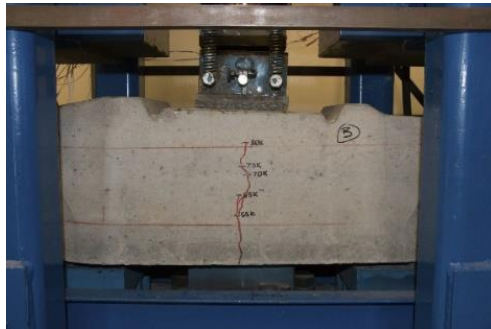

# Strain to Moment Laboratory Calibration

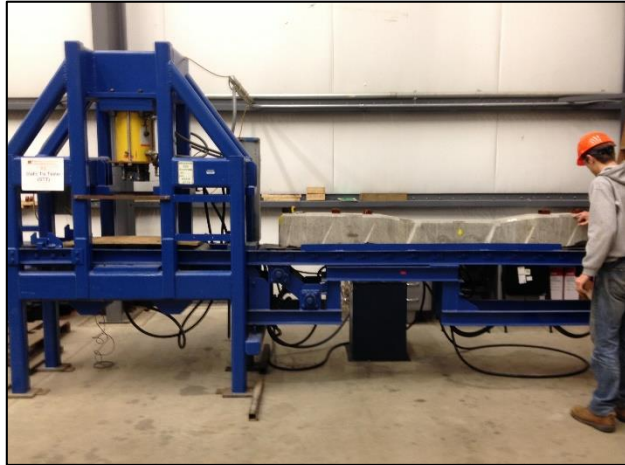

Known moment applied with Static Tie Tester (STT) to crosstie in controlled loading configurations, record bending strain and find slope of curve

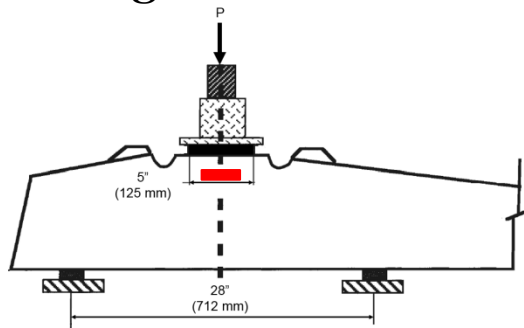
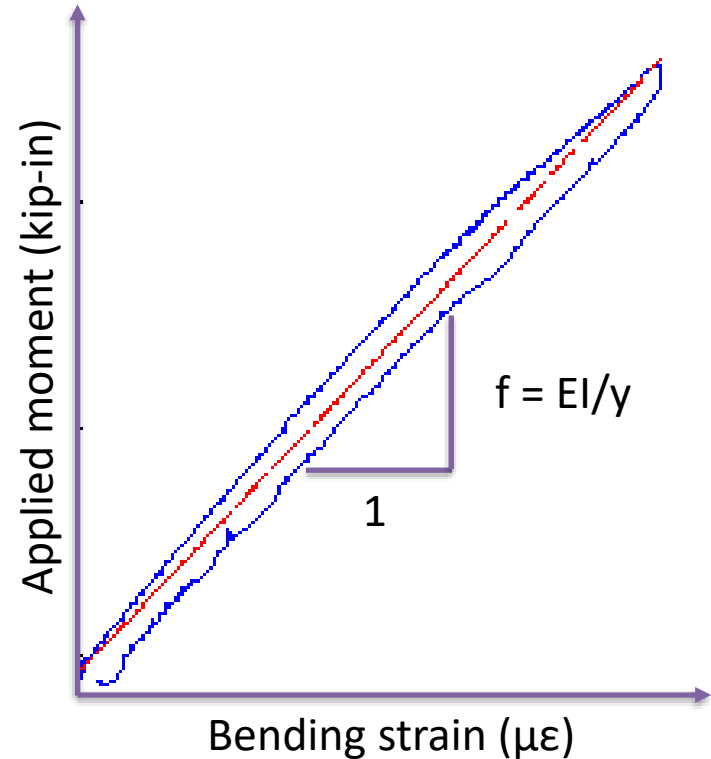

Rail Seat Positive

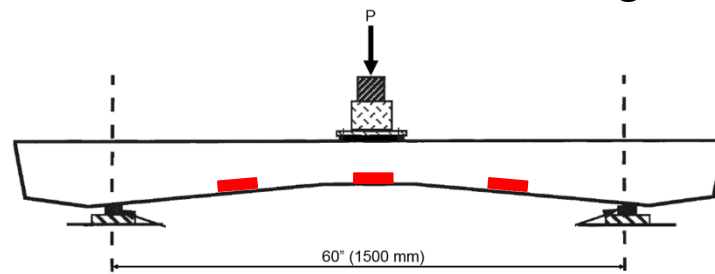

Center Negative





# Laboratory Experimentation Equipment

- Loading frame - Static Load Testing Machine (SLTM)

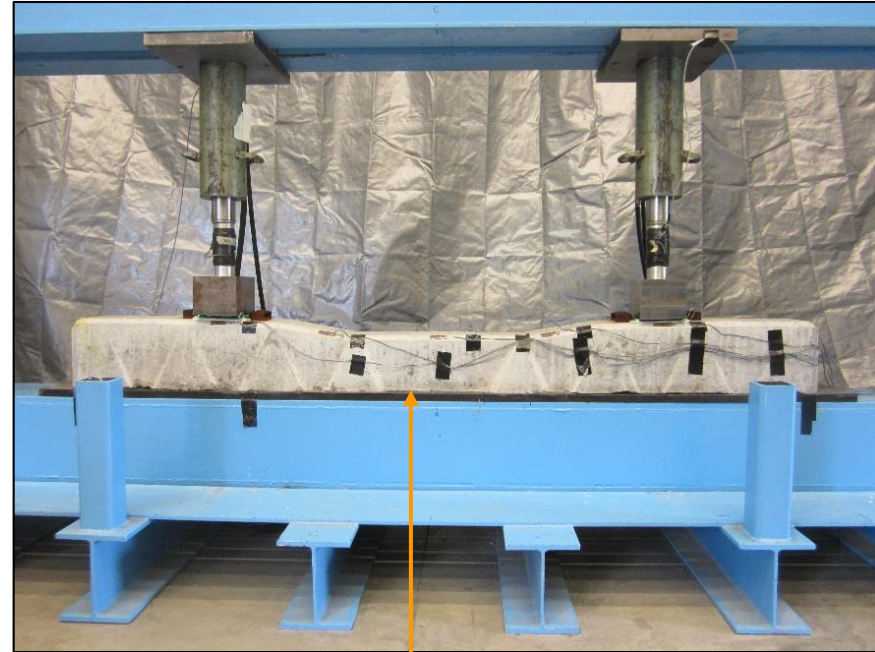
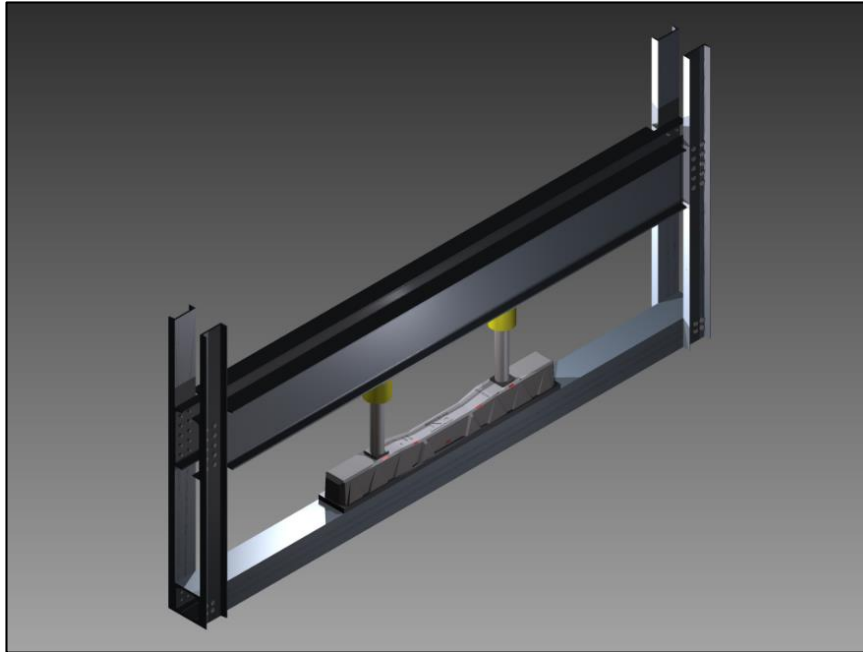

- Supporting rubber pads

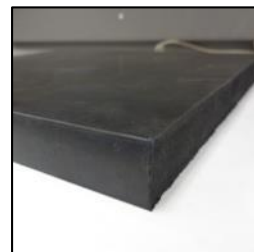

# Flexural Performance under Different Support Conditions

*Rail Seat Load: 20 kips (89 kN), Healthy Crosstie*

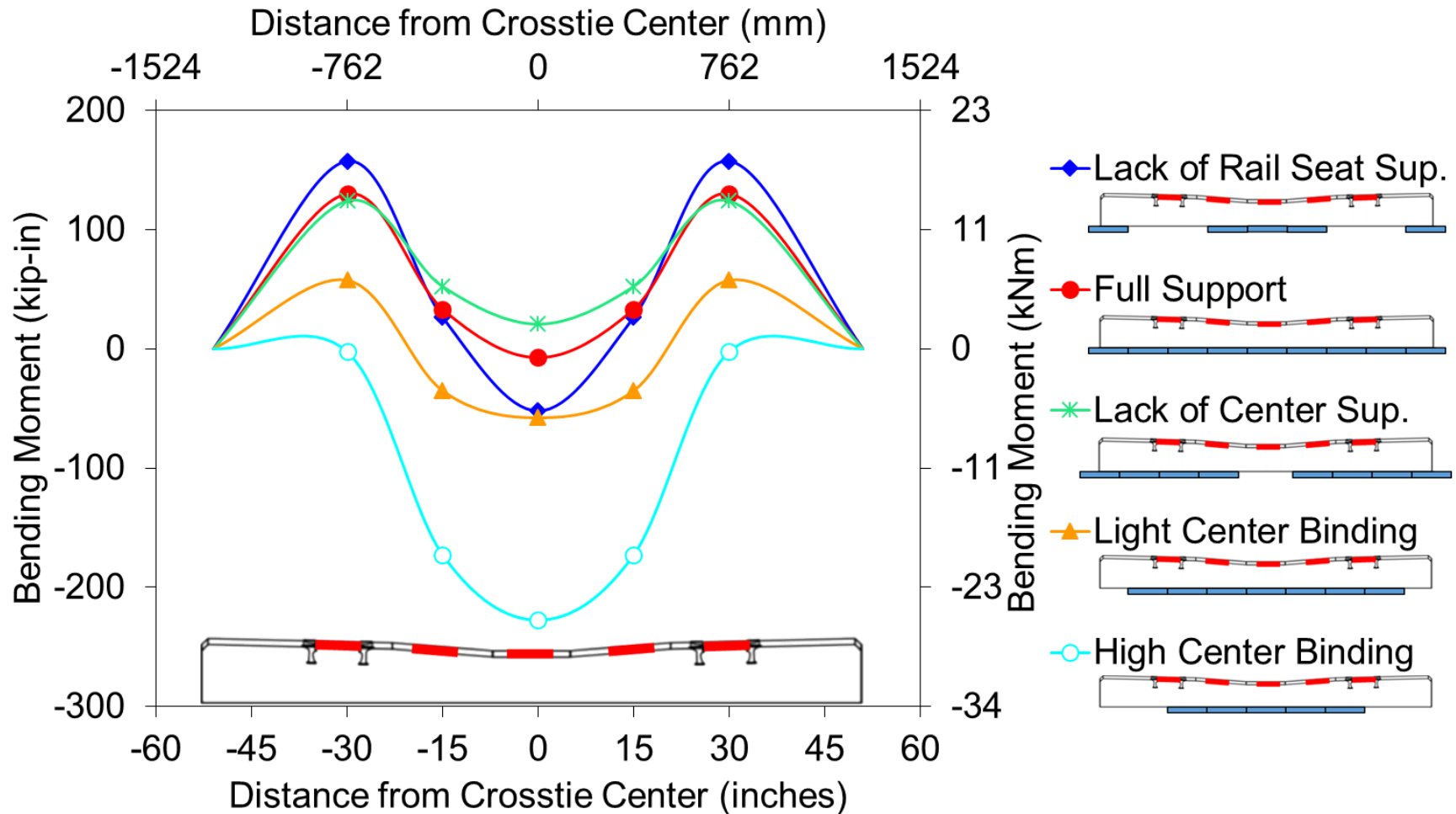

# Laboratory Experimentation: Preliminary Conclusions

- Small amounts of center binding can result in large differences in center moment:
  - 241.2 kip-in change for high center binding (at center)
  - 78.6 kip-in change for light center binding (at center)
- Rail seat moments are less sensitive to changes in support:
  - 33.4 kip-in change for lack of rail seat support (at rail seat)
- Center negative cracks are more likely than rail seat positive cracks and support conditions play a major role in the crosstie performance

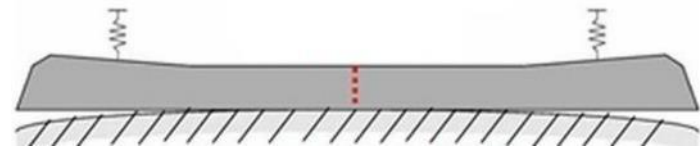
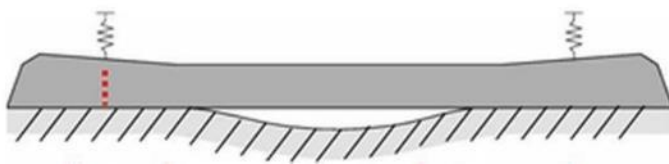

# Outline

- Background and motivation
- FRA laboratory experimentation
- **Field experimentation**
- Ballast support back-calculator
- Conclusions
- Future work



# Field Site Layout

- Site split into two zones of five crossties each
- Concrete surface strain gauges installed on 10 crossties

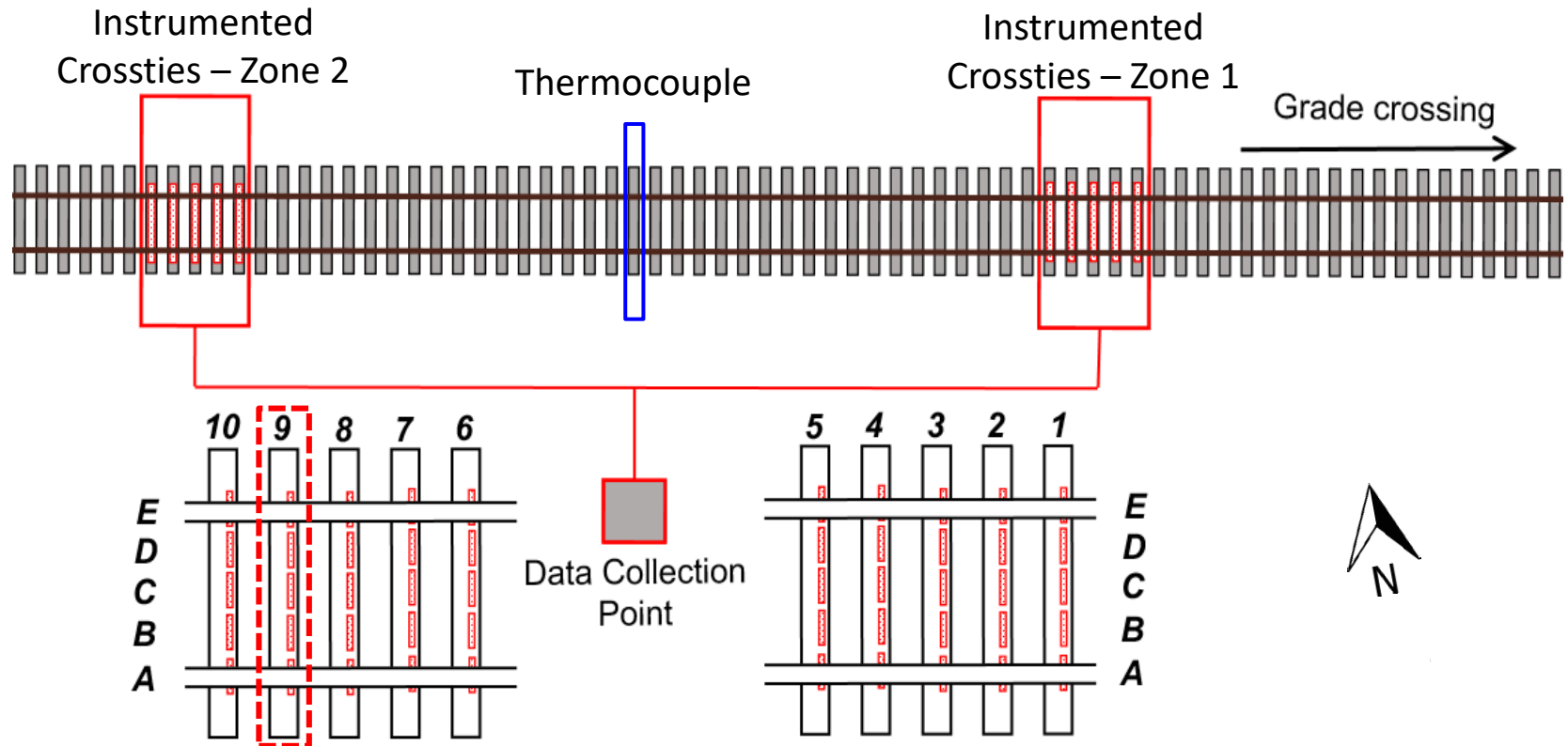

# Instrumentation Protection Plan

- Surface strain gauges are delicate sensors and must be protected
- Potential types of damage:
  - Mechanical damage - impacts or pressures caused by train passes or maintenance activities
  - Moisture damage - ingress of water can cause wire shorts and failures

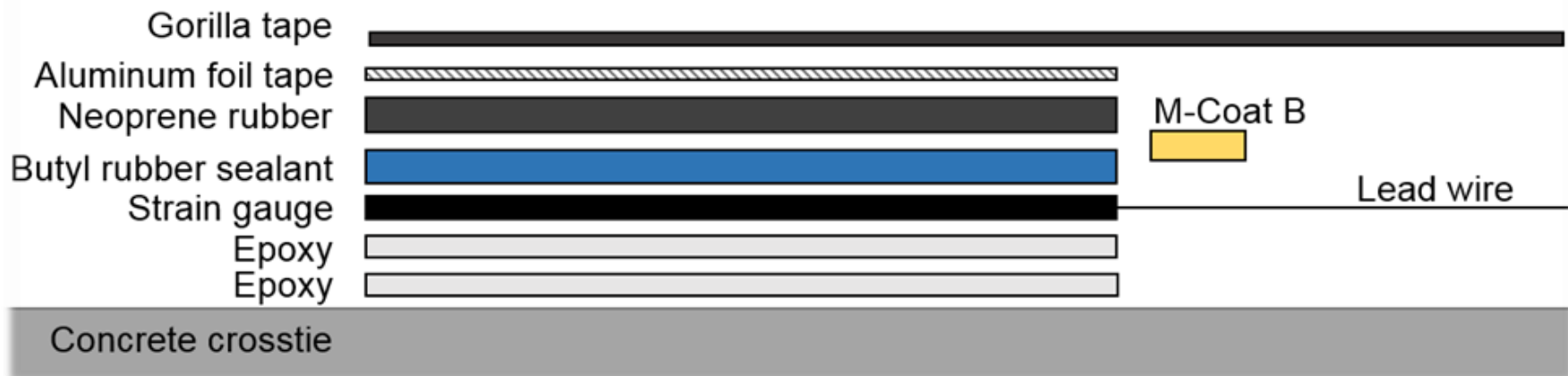

# Example Strain Signal (Gauge C)

- Strain peaks correspond to loaded axles

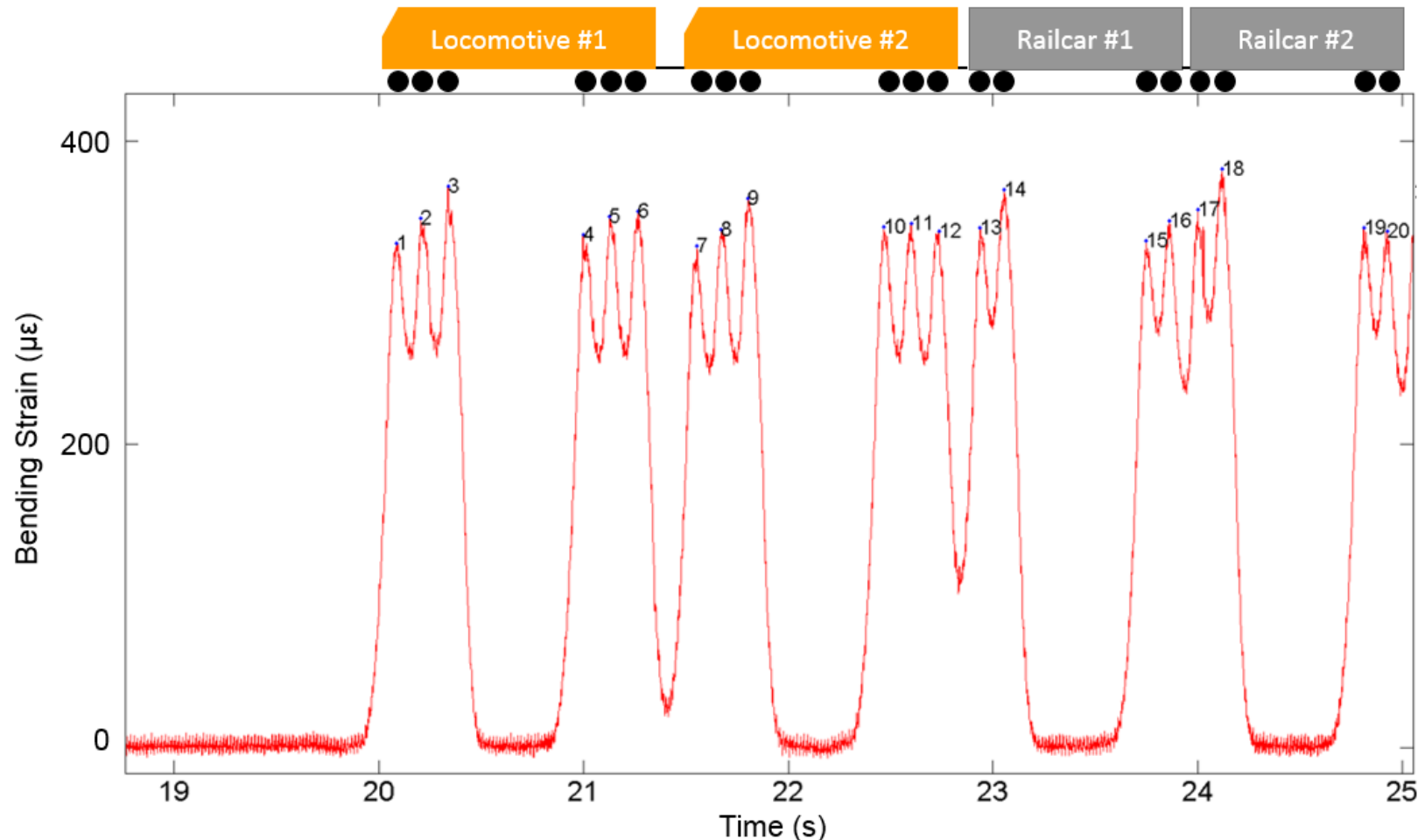

# Average Center Negative Bending Moment vs. Time/Tonnage (Gauge C)

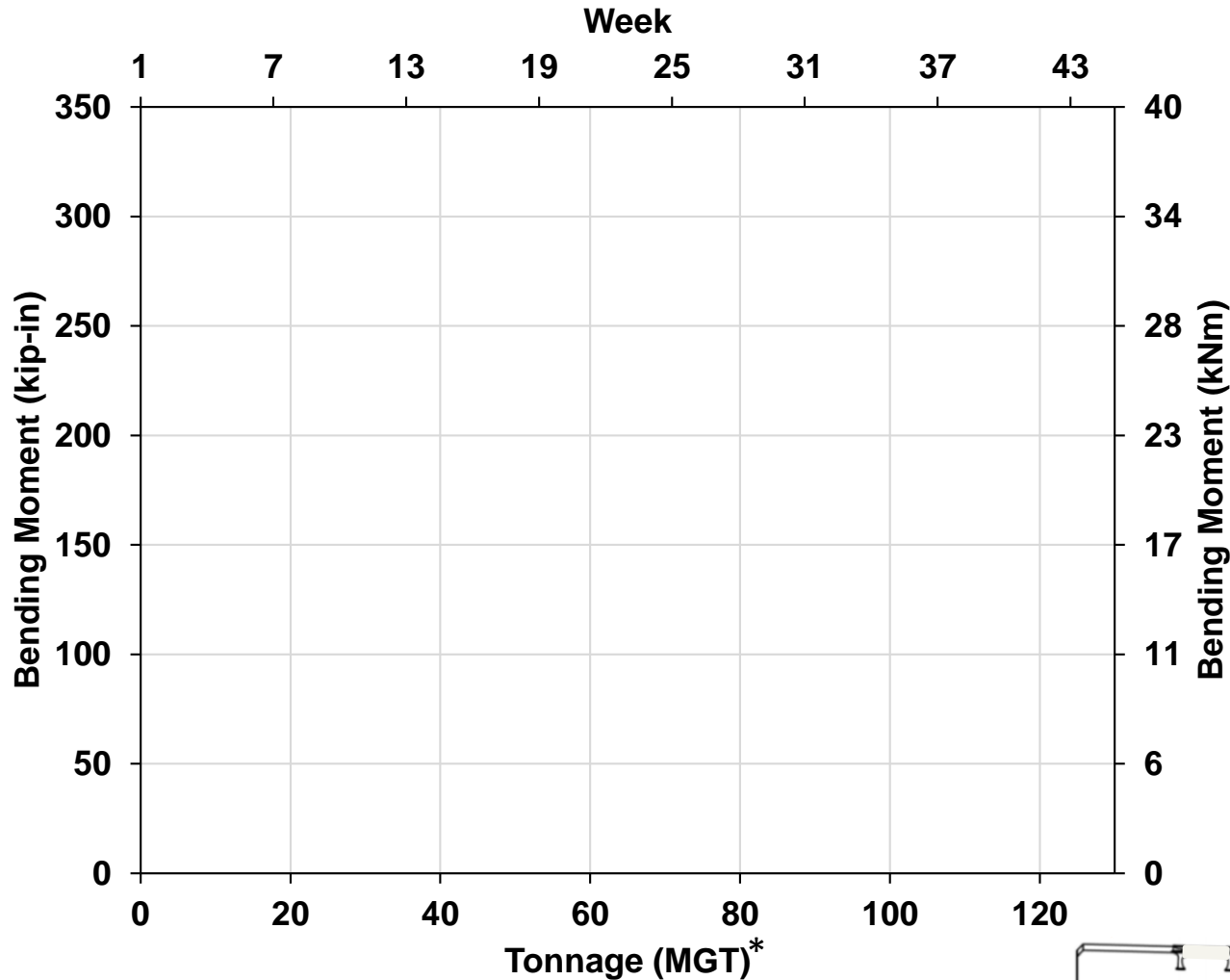



# Average Center Negative Bending Moment vs. Time/Tonnage (Gauge C)

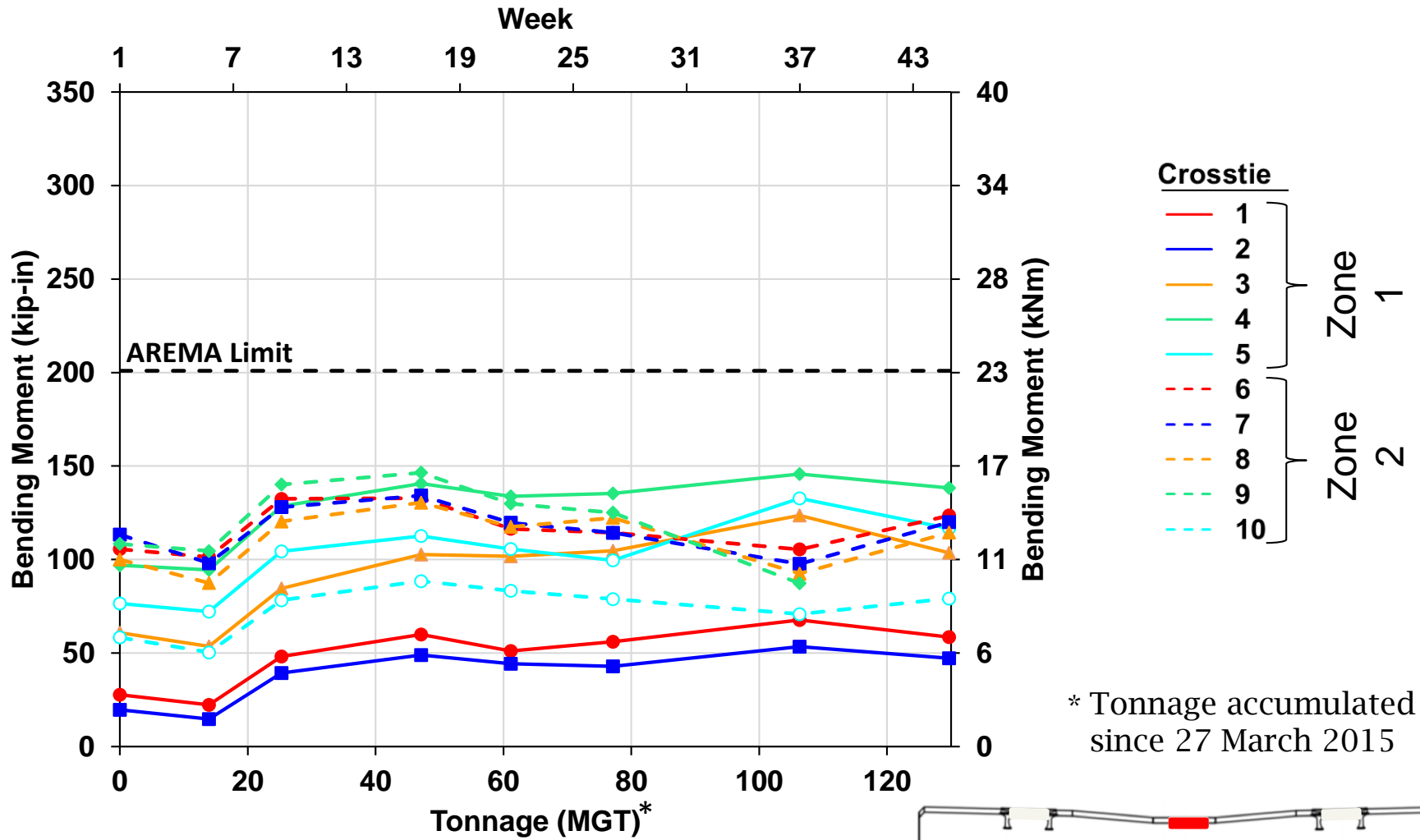

\* Tonnage accumulated since 27 March 2015

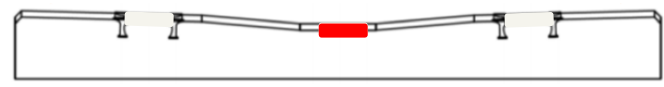

AREMA 2016 Annual Conference & Exposition



# Average Rail Seat Positive Bending Moment vs. Time/Tonnage (Gauge A & E)

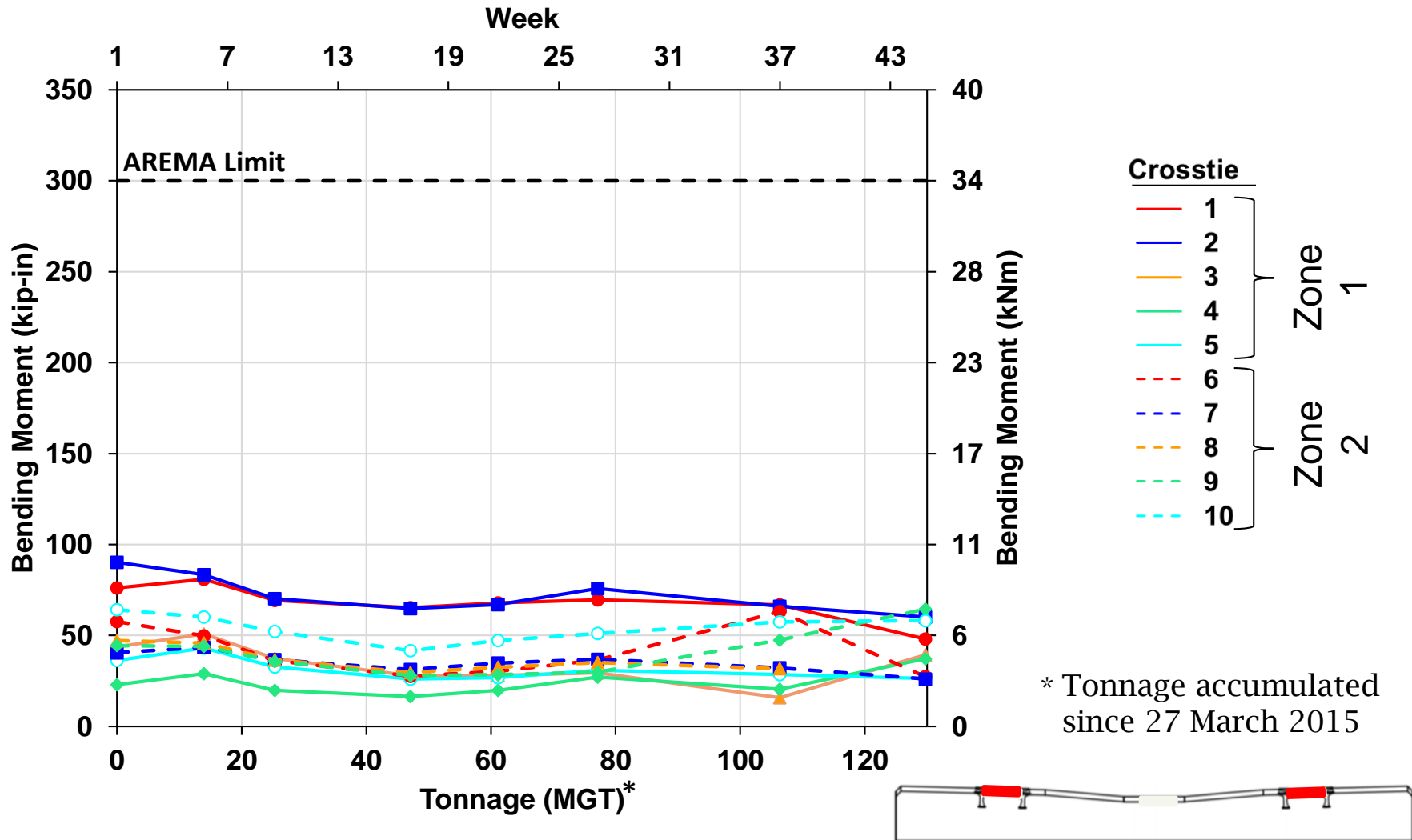

# Box Plot Background

- Box plots are great to:
  - Visualize outliers
  - Compare variability of different cases
  - Check for symmetry
  - Check for normality

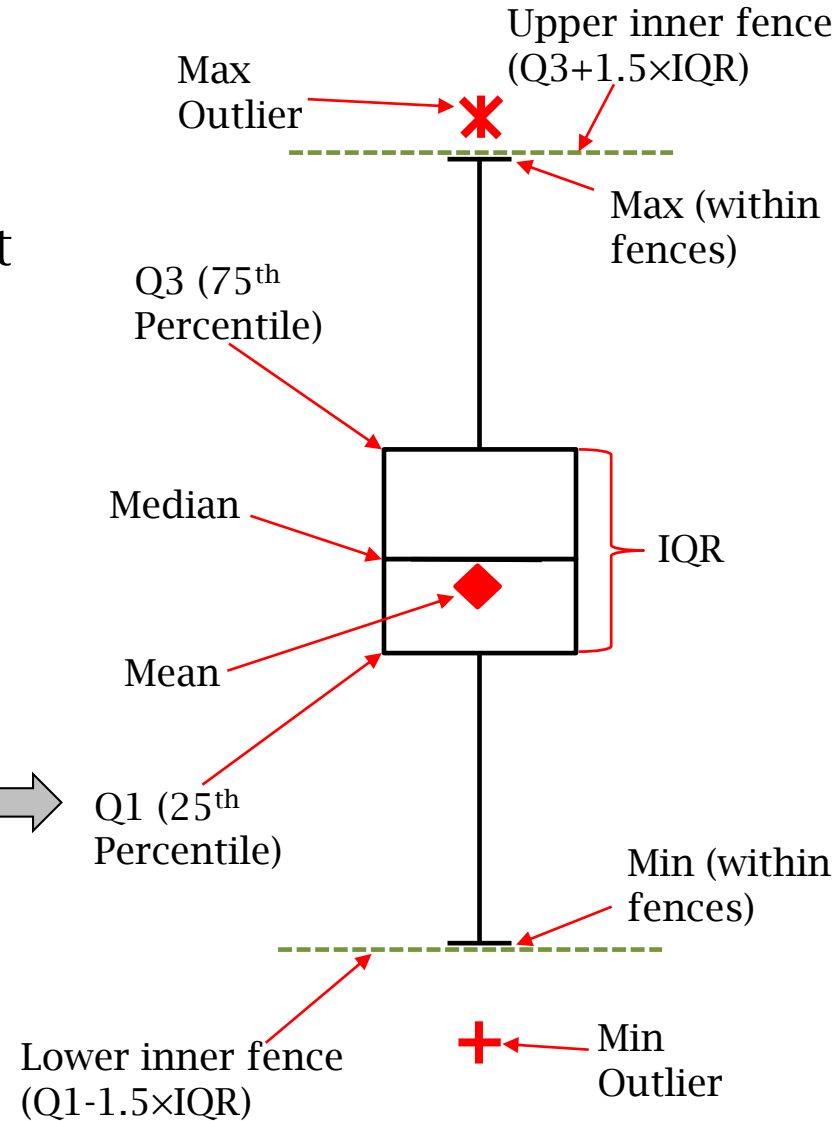
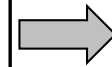
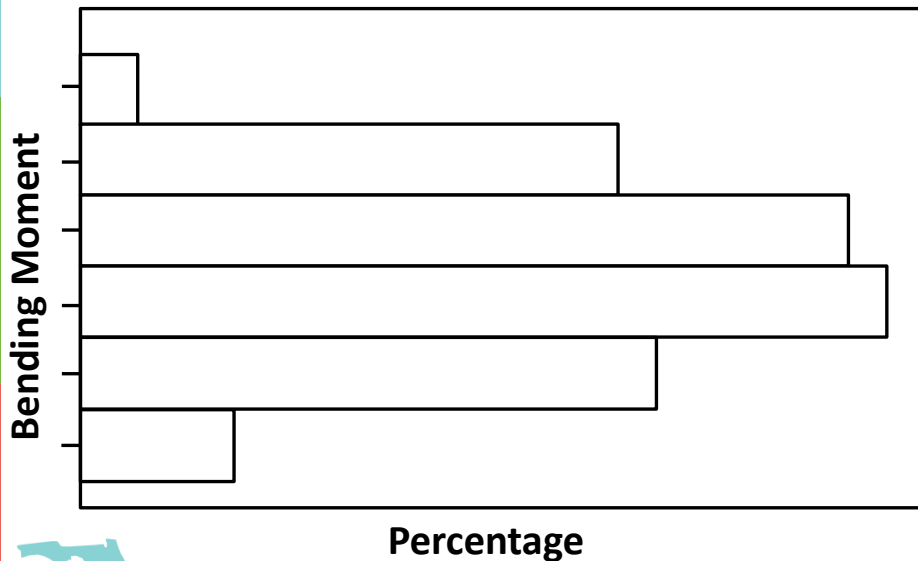

# Box Plot for Center Negative Bending Moment (Gauge C)

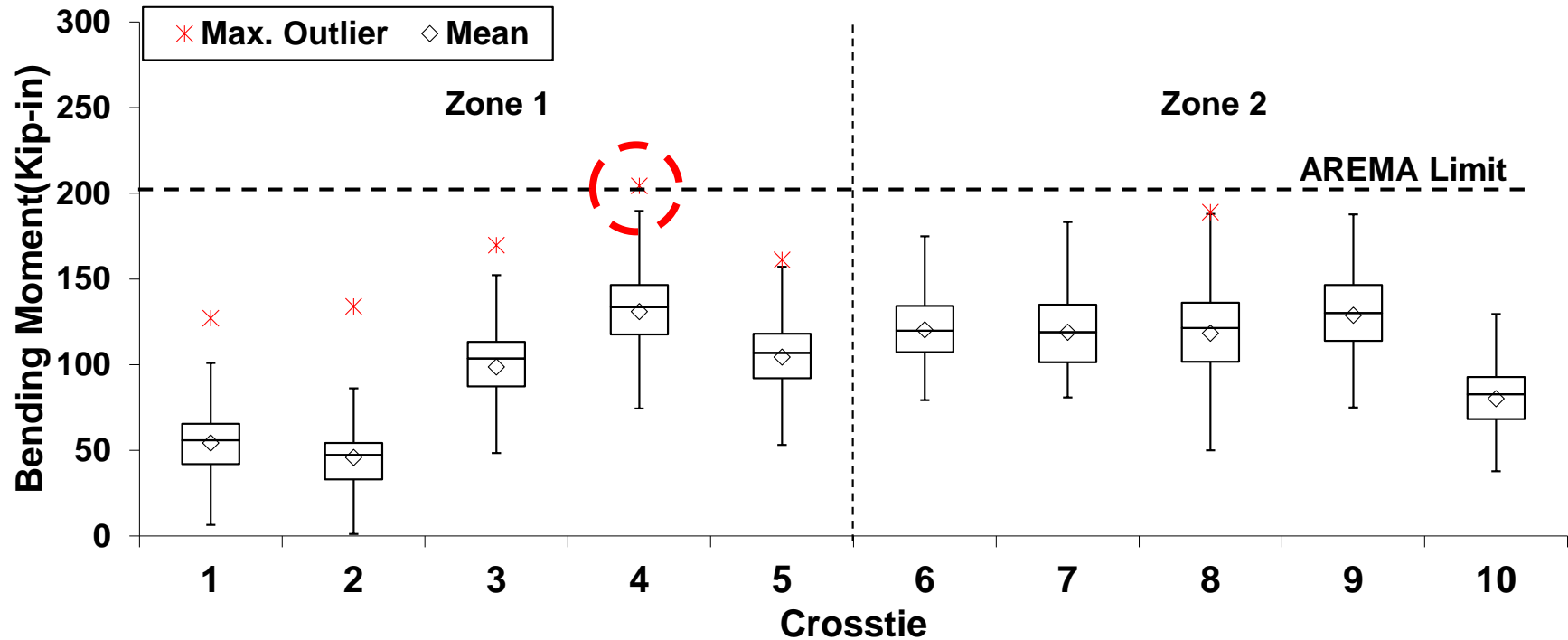

- However, only 2 of 38,954 loaded axles exceeded the AREMA limit
  - 0.005% exceedance probability for Crosstie 4 and 0.0005% for all 10 crossties



# Box Plot for Rail Seat Positive Bending Moment (Gauge A & E)

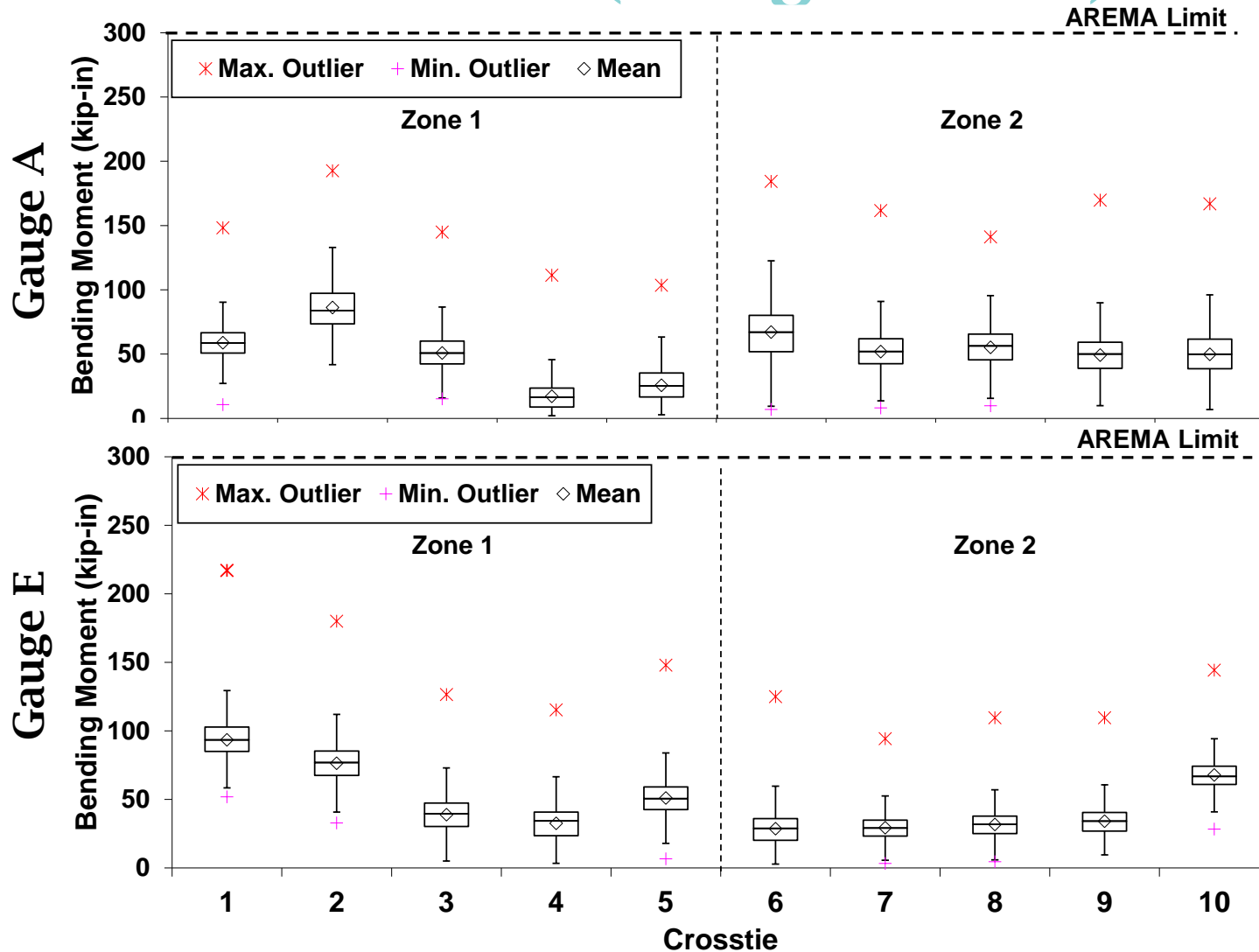

# Outline

- Background and motivation
- FRA laboratory experimentation
- Field experimentation
- **Ballast support back-calculator**
- Conclusions
- Future work



# 2-D Crosstie Bending Model

- Assume rail seat load is uniformly distributed across rail seat
- Divide the crosstie into 6 bins:
  - Each bin consists a percentage of total reaction force
- 9 inputs:
  - Known bending moments from 7 locations
  - 2 approximated rail seat loads
- 2 boundary conditions:
  - Force equilibrium (sum of all bins should be close to 1)
  - Value of each bin should not be negative

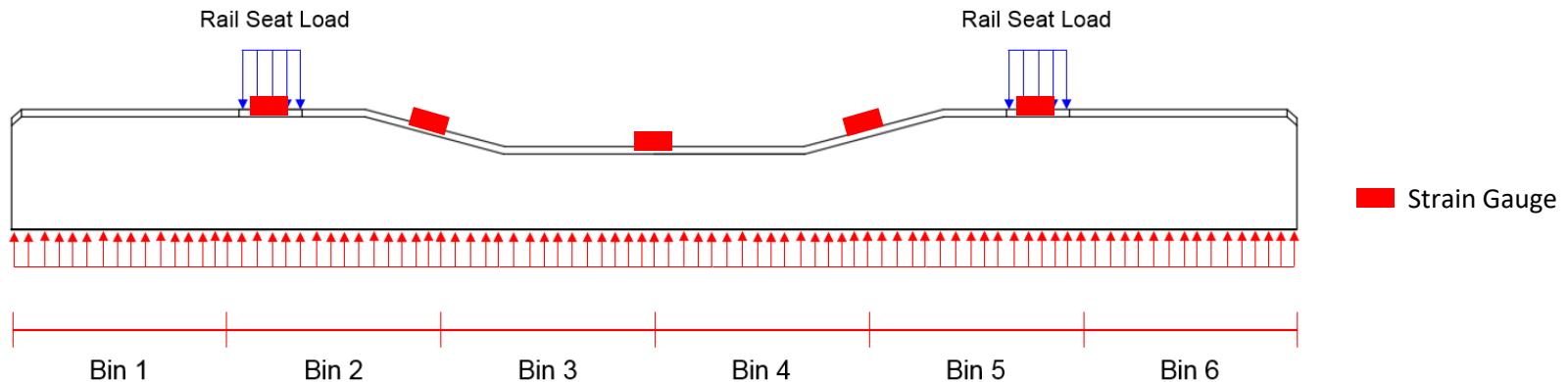

# Ballast Pressure Limit States

- Ballast pressure calculated based on uniform support condition: 32 psi
- AREMA allowable ballast surface stress under concrete crossties: 85 psi
- Ballast pressure calculated based on AREMA allowable subgrade bearing stress (25 psi) using Talbot equation: 55psi

$$h = \left( \frac{16.8p_a}{p_c} \right)^{4/5}$$

Where, h = Support ballast depth

$p_a$  = Stress at bottom of tie (top of ballast)

$p_c$  = Allowable subgrade stress





# Distribution of Ballast Reaction for Crosstie 8, 9, and 10

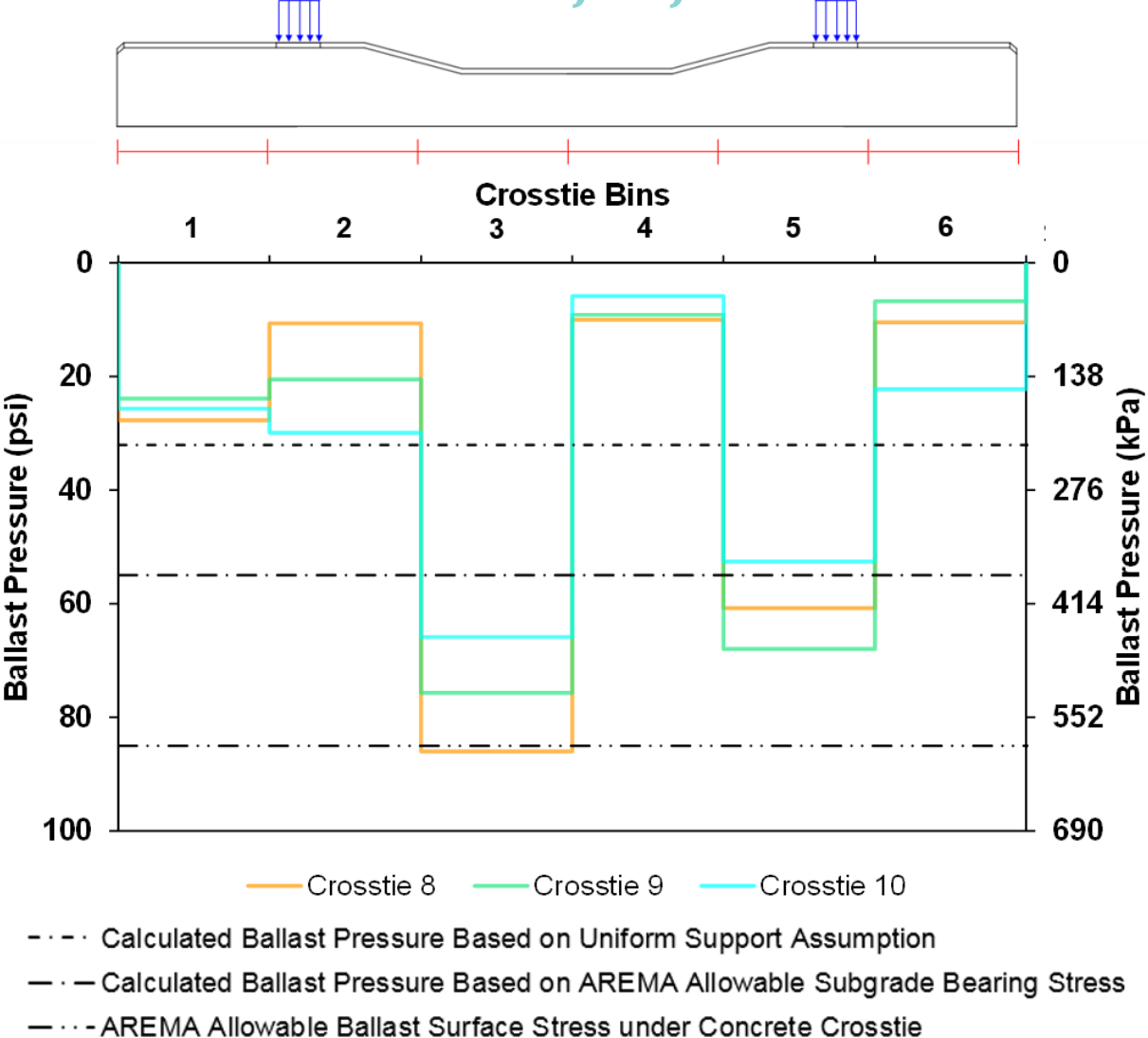

# Outline

- Background and motivation
- FRA laboratory experimentation
- Field experimentation
- Ballast support back-calculator
- **Conclusions**
- Future work

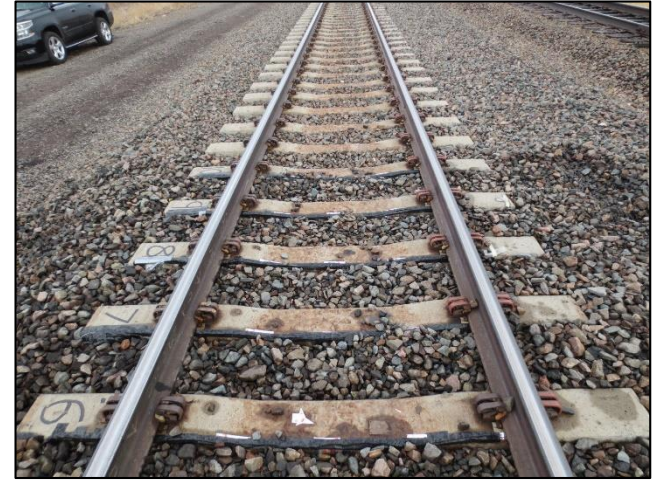

# Conclusions

## Laboratory and Field Findings

- Lab experimentation suggested crossties' bending behavior was sensitive to support conditions
  - Center bending was more sensitive
- Field instrumentation was proven to be successful
  - No failure over 10 month period or accumulation of 100 MGT
- Field-measured moments in a properly maintained track were relatively stable over 100 MGT
- Center negative bending moments approached AREMA recommended design limits

## Resulting Design Implications

- AREMA Committee 30 currently finalizing new design approach which will increase C- and decrease RS+
- UIUC developing support back-calculator to better identify crosstie support conditions to further improve crosstie/track design and maintenance recommendations



# Future Work

- Dynamic laboratory experimentation
  - Crack initiation and propagation
- Continue field data collection and data analysis
  - Collect data before and after tamping
  - Collect data at various locations, under various modes of traffic, and with varying crosstie designs
- Refine ballast support condition back-calculator



# Acknowledgements



- Funding for this research has been provided by:
  - National University Rail (NURail) Center, a US DOT-OST Tier 1 University Transportation Center
  - Federal Railroad Administration (FRA)
- Industry Partnership and support has been provided by
  - Union Pacific Railroad
  - BNSF Railway
  - National Railway Passenger Corporation (Amtrak)
  - Progress Rail Services
  - GIC Ingeniería y Construcción
  - Hanson Professional Services, Inc.
  - CXT Concrete Ties, Inc., LB Foster Company
  - TTX Company
- For assistance with lab/field testing and data processing
  - Josué Bastos and Quinn Todzo

## FRA Tie and Fastener BAA Industry Partners:



**BUILDING AMERICA®**



**AREMA 2016 Annual Conference & Exposition**

# Any Questions?



**Zhengboyang Gao**

*Graduate Research Assistant*

email: zgao9@Illinois.edu

**J. Riley Edwards**

*Senior Lecturer and Research Scientist*

email: jedward2@illinois.edu

**Marcus S. Dersch**

*Senior Research Engineer*

email: mdersch2@illinois.edu

**Yu Qian**

*Research Engineer*

email: yuqian1@illinois.edu



AREMA 2016 Annual Conference & Exposition

