

IMPROVING THE EFFICIENCY AND EFFECTIVENESS OF RAILCAR SAFETY  
APPLIANCE INSPECTIONS USING MACHINE VISION TECHNOLOGY

BY

JOHN RILEY EDWARDS

B.E., Vanderbilt University, 2004

THESIS

Submitted in partial fulfillment of the requirements  
for the degree of Master of Science in Civil Engineering  
in the Graduate College of the  
University of Illinois at Urbana-Champaign, 2006

Urbana, Illinois



## ABSTRACT

# IMPROVING THE EFFICIENCY AND EFFECTIVENESS OF RAILCAR SAFETY APPLIANCE INSPECTIONS USING MACHINE VISION TECHNOLOGY

John Riley Edwards, M.S.  
Department of Civil and Environmental Engineering  
University of Illinois at Urbana-Champaign  
Christopher P.L. Barkan, Ph.D., Advisor

Machine vision technology has the potential to substantially improve the efficiency and effectiveness of railcar safety appliance inspection by increasing the speed, accuracy, and objectivity of the process. Laboratory and field studies were conducted to develop and successfully demonstrate the feasibility of its use for safety appliance inspection. Safety appliances are used by railroad employees to mount and dismount cars, apply and release hand brakes, uncouple cars, and perform other duties related to safe and efficient railway operation. Maintaining them in proper working order is required by the Federal Railroad Administration (FRA) and regulations specify their proper condition. Safety appliances are inspected every time a railcar departs a rail yard and at times between yards. These inspections are a manual, labor-intensive process. Data were analyzed to understand the scope of safety appliance deformation and defects, where they occur, how many fatalities and injuries they cause, the cost of repairs, differences in inspection procedures, and the regulations governing inspections. A simple, qualitative model was developed of the effect of technology enhancement on the economic efficiency of inspection.

Extensive development and field testing was conducted of a digital video acquisition system that enabled collection of images suitable for analysis using machine vision algorithms. Camera angles were studied to determine the optimal view that maximized the utility of the images while minimizing the number of cameras required to analyze ladders, handholds, and brake wheels on high-sided gondolas and hopper cars. Safety appliances were experimentally damaged on a railcar at the Transportation Technology Center (TTC). The car was operated in a test train and digital images acquired in a manner similar to how a permanent field installation would function. The image acquisition system successfully detected the pertinent safety appliances as well as deformations and FRA defects. The machine vision algorithms were found to be sensitive to lighting conditions and it is likely that some means of controlling these will be required for permanent installations.

It is anticipated that visual learning will be used to develop the algorithms that detect deformations and defects and a very large number of images will be needed to train the algorithm. Instances of safety appliance deformation, and especially defects, are relatively uncommon on actual railcars; therefore, a virtual, three-dimensional model of a railcar and its safety appliances was developed using 3DS MAX 8 to create images. The model enables virtual deformation of any part of the car, as well as manipulation of lighting conditions, camera viewing angle, and background conditions, thereby expediting development of the algorithms and enabling testing of various approaches to image acquisition.

An interim system for safety appliance inspection is considered that would enable railroads to derive some of the benefits of machine vision inspection prior to complete development of all of the algorithms necessary to inspect all appliances on all cars. Finally, safety appliance regulations are considered as they relate to machine vision inspection of safety appliances compared to visual inspection and a preliminary assessment of the issues and requirements for automated inspection of other safety appliances is presented.

*To*  
*John and Paula Edwards*

## **ACKNOWLEDGEMENTS**

I would like to thank all of the people who have encouraged me to pursue a career in the railroad industry as well as those who have made this thesis possible. I am grateful to David Davis, Jim Robeda, Jim Lundgren and Joseph LoPresti of Transportation Technology Center, Inc., Pat Ameen of AAR, Bill Blevins, Darrel Hoyt, and Mike Smith of CN, Ryan Miller, Paul Gabler, Larry Milhon, and Hank Lees of BNSF, Gary Nelson, John Sigler, Todd Comer, Bruce King, and Hayden Newell of Norfolk Southern, Steve Phebus and Mike Cipriani of CSX, Tom Dalrymple of Trinity Rail, and Dr. Narendra Ahuja, Sinisa Todorovic, John M. Hart, Ze Ziong Chua, Nick Kocher, and John Zeman of the University of Illinois for their assistance and cooperation with the research that went into the preparation of this thesis. Principal support for this research was from the Association of American Railroads Technology Scanning Program. Additional support was provided by the BNSF Railway Technical Research and Development program. I am grateful to CN for supporting me for the year 2004-2005 with a CN Railroad Research Fellowship.

I am grateful to my classmates for their advice and time regarding this thesis as well as their friendship over the past two years. I would also like to thank my advisor, Dr. Chris Barkan, for his encouragement and guidance throughout this research project. Finally, I am also grateful to my parents, who allowed our family vacations and other family time to be tailored around my love of transportation.

## TABLE OF CONTENTS

LIST OF TABLES .....	xiii
LIST OF FIGURES .....	xiv
CHAPTER 1: INTRODUCTION .....	1
1.1 Background on Railroad Safety Appliances and Safety Appliance Inspection.....	1
1.2 History of Railroad Safety Appliances .....	3
CHAPTER 2: QUANTIFICATION OF APPLIANCE DEFECT TYPES AND OCCURANCE.....	10
2.1 Quantification Methods .....	10
2.2 FRA Inspection Database .....	11
2.3 Class I Railroad Bad Order Data .....	13
2.4 AAR Repair Data.....	19
2.5 FRA Casualty Database .....	20
2.6 FRA Accident Database.....	21
2.7 Switching Operations Fatality Analysis Data.....	22
2.8 Opportunity Costs Due to Cars Being Out of Service .....	24
2.9 Summary of Safety Appliance Data .....	25
CHAPTER 3: RAILROAD CAR INSPECTIONS.....	26
3.1 Introduction.....	26
3.2 Car Inspectors .....	26
3.3 Inspection Duration.....	27
3.3.1 FRA Estimate of Inbound Inspection Duration .....	27
3.3.2 Class I Railroad Estimate of Inspection Duration.....	29
3.3.3 AAR Estimate of Inspection Duration.....	29
3.3.4 Summary of Inspection Duration Estimates .....	29
3.4 Inspection Cost .....	30
3.5 Regulations Governing the Inspection and Repair of Railcars.....	30
3.5.1 FRA CFR Part 215 – The Freight Car Safety Standards .....	32
3.5.2 FRA CFR Part 231 – The Railroad Safety Appliance Standards .....	33



3.5.3 <i>FRA CFR Part 232 – Brake System Safety Standards for Freight and Other Non-Passenger Trains and Equipment</i> .....	33
3.6 Statutory Requirements for Railcars.....	33
3.7 Inspection Jurisdiction .....	36
3.8 Types of Car Inspections .....	37
3.8.1 <i>Air Brake Inspections</i> .....	37
3.8.2 <i>Inbound Car Inspections</i> .....	38
3.8.3 <i>Pre-Departure Inspections</i> .....	39
3.8.4 <i>Other Inspection Types</i> .....	41
3.9 Sample Inspection Types for one Class I railroad .....	41
3.10 Safety Appliance Use.....	43
3.11 Bad Order Options .....	44
3.12 Current Railroad Car Inspection Process.....	46
3.13 Train Inspections and Yard Efficiency .....	48
<b>CHAPTER 4: RAILROAD SAFETY APPLIANCE STANDARDS, CFR</b>	
PART 231 .....	50
4.1 Handbrakes .....	51
4.2 End Platforms .....	52
4.3 Sill Steps .....	53
4.4 End Ladder clearance.....	53
4.5 Side Handholds .....	54
4.6 End Handholds.....	54
4.7 Horizontal End-Platform Handholds .....	55
4.8 Uncoupling Levers.....	56
<b>CHAPTER 5: SAFETY APPLIANCE INSPECTION COST MODEL .....</b>	
5.1 Introduction to the Industrial Inspection Process .....	57
5.2 Types of Industrial Inspection Processes.....	59
5.3 Relationship Between Inspection Rate and Defect Detection .....	59
5.4 Qualitative Inspection Cost Model .....	62
5.4.1 <i>Failure Costs</i> .....	63
5.4.2 <i>Improvement Costs</i> .....	63

5.4.3 Total Costs .....	65
5.5 Qualitative Inspection Cost Model after the Addition of New Technologies to the Inspection Process .....	66
CHAPTER 6: METHODS OF IMPROVING THE EFFICIENCY AND EFFECTIVENESS OF RAILROAD SAFETY APPLIANCE INSPECTIONS .....	68
6.1 Machine Vision Overview .....	68
6.2 Comparison of Human Vision and Machine Vision.....	69
6.3 Automation and Memory.....	70
CHAPTER 7: MACHINE VISION SYSTEM FOR THE DETECTION OF SAFETY APPLIANCE DECECTS.....	72
7.1 Machine Vision System Locational Requirements.....	72
7.2 Camera View .....	75
7.2.1 Perpendicular Side View.....	75
7.2.2 Perpendicular Overhead View.....	76
7.2.3 Angled Overhead View .....	77
7.2.4 Angled Side View .....	78
7.2.5 Upward Angled Side View .....	79
7.3 Camera Angle .....	81
7.4 Image Acquisition System .....	84
7.5 Machine Vision Algorithm .....	85
7.6 Frame Rate and Train Speed.....	90
7.7 Methods for Obtaining Images of Deformed Railcar Safety Appliances.....	92
7.7.1 Manual Deformation of Railcar Safety Appliances.....	92
7.7.2 Three Dimensional Modeling of Railcar Safety Appliances.....	92
7.8 Challenges and Considerations in using Machine Vision to Inspect Safety Appliances .....	96
7.9 Other Methods of Detecting Safety Appliance Defects.....	98
7.9.1 Comparison of Opposite Corners .....	98
7.9.2 Analysis of Shadows to Determine Ladder Rung and Handhold Clearance.....	101
7.10 Future Work Prioritization.....	102

7.10.1	<i>Prioritization of Additional Safety Appliances</i>	102
7.10.2	<i>Prioritization of Additional Car Types</i>	102
CHAPTER 8: INTERIM APPROACH TO MACHINE VISION		
INSPECTION OF RAILCAR SAFETY APPLIANCES		106
8.1	Overview of Interim System	106
8.2	Installation	106
8.3	Image Analysis	108
CHAPTER 9: SAFETY APPLIANCE PARAMETERS FOR MACHINE		
VISION DETECTION		112
9.1	Overview of Parameters	112
9.2	Handbrake	114
9.2.1	<i>Handbrake Design Parameters (FRA 2004b)</i>	115
9.2.2	<i>Brake Wheel Dynamic Parameters (FRA 2004b)</i>	117
9.2.3	<i>Brake Wheel Machine Vision Image Considerations</i>	117
9.3	Brake Step	120
9.3.1	<i>Brake Step Design Parameters (FRA 2004b)</i>	120
9.3.2	<i>Brake Step Dynamic Parameters (FRA 2004b)</i>	122
9.3.3	<i>Brake Step Machine Vision Image Considerations</i>	122
9.4	Sill Steps	125
9.4.1	<i>Sill Step Design Parameters (FRA 2004b)</i>	126
9.4.2	<i>Sill Step Dynamic Parameters (FRA 2004b)</i>	127
9.4.3	<i>Sill Step Machine Vision Image Considerations</i>	127
9.5	Ladders	130
9.5.1	<i>Ladder Design Parameters (FRA 2004b)</i>	130
9.5.2	<i>Ladder Dynamic Parameters (FRA 2004b)</i>	132
9.5.3	<i>Ladder Machine Vision Image Considerations</i>	132
9.6	Side Handholds	134
9.6.1	<i>Side Handhold Design Parameters (FRA 2004b)</i>	134
9.6.2	<i>Side Handhold Dynamic Parameters (FRA 2004b)</i>	135
9.6.3	<i>Side Handhold Machine Vision Image Considerations</i>	135
9.7	Horizontal End Handholds	137

9.7.1 <i>Horizontal End Handhold Design Parameters (FRA 2004b)</i> .....	137
9.7.2 <i>Horizontal End Handhold Dynamic Parameters (FRA 2004b)</i> .....	139
9.7.3 <i>Horizontal End Handhold Machine Vision Image Considerations</i> .....	139
9.8 Vertical End Handholds.....	140
9.8.1 <i>Vertical End Handhold Design Parameters (FRA 2004b)</i> .....	140
9.8.2 <i>Vertical End Handhold Dynamic Parameters (FRA 2004b)</i> .....	140
9.8.3 <i>Vertical End Handhold Machine Vision Image Considerations</i> .....	140
9.9 Uncoupling Levers.....	141
9.9.1 <i>Uncoupling Lever Design Parameters (FRA 2004b)</i> .....	141
9.9.2 <i>Uncoupling Lever Dynamic Parameters (FRA 2004b)</i> .....	142
9.9.3 <i>Uncoupling Lever Machine Vision Image Considerations</i> .....	142
9.10 End Ladder Clearance.....	143
9.10.1 <i>End Ladder Clearance Design Parameters (FRA 2004b)</i> .....	143
9.10.2 <i>End Ladder Clearance Dynamic Parameters (FRA 2004b)</i> .....	143
9.10.3 <i>End Ladder Clearance Machine Vision Image Considerations</i> .....	144
CHAPTER 10: CONCLUSION .....	145
10.1 Summary.....	145
10.2 Future Research and Issues.....	146
REFERENCES .....	148
APPENDICES .....	152
APPENDIX A – Inbound Car Inspection Priorities .....	152

## LIST OF TABLES

Table 2.1 Safety appliance bad order symbols for one Class I railroad .....	19
Table 2.2 Summary of Safety Appliance Defect Data.....	25
Table 3.1 Inspection types and corresponding inspection symbols for an example Class I railroad.....	41
Table 3.2 Data from one Class I railroad yard representing parameters that are monitored with respect to the car inspection process .....	43
Table 6.1 Comparison of relative advantages and disadvantages of human and machine vision (Batchelor 2005) .....	70
Table 7.1 Summary table of views considered in photographing safety appliances.....	81
Table 7.2 Car Types and Codes showing the average number of passes by a WILD site between October 2004 and November 2005.....	104

## LIST OF FIGURES

Figure 1.1 Picture of the end of a covered hopper car showing the safety appliances: sill step, side and end ladder, brake step, side and end handholds, and the brake wheel .....	1
Figure 2.1 FRA safety appliance defects found by FRA inspectors between 1995 and 2004 grouped by major rule of CFR Part 231 .....	12
Figure 2.2 Safety appliance defect ratios from FRA safety appliance inspections for the ten year period of 1995-2004 .....	13
Figure 2.3 Comparisons of FRA and Class 1 railroad safety appliance defects by car type.....	15
Figure 2.4 Comparison of safety appliance defects at two Class 1 railroad yards .....	16
Figure 2.5 Distribution of safety appliance bad order rates at 60 locations on one Class I railroad .....	17
Figure 2.6 Specific appliances bad ordered on one Class I railroad during October and November of 2005.....	18
Figure 3.1 Comparison of the percentage of cars inspected by each inspection type at two Class I railroad yards.....	42
Figure 3.2 Bad order card for a sample Class I railroad .....	45
Figure 3.3 Three different approaches to inspection at three Class I rail yards.....	47
Figure 5.1 Functional relationship between percent of defects escaping detection and inspection rate of a human inspecting using 100% inspection (Kennedy and Andrews 1977) .....	61
Figure 5.2 Qualitative model of optimum inspection costs as inspections are currently performed ( $P_0$ and $C_0$ ) (Kennedy and Andrews 1977) .....	65
Figure 5.3 Qualitative model of optimum inspection costs after the addition of additional technology to safety appliance inspections ( $P_1$ and $C_1$ ) (adopted from Kennedy and Andrews 1977).....	67
Figure 7.1 Perpendicular view of the railcar.....	76
Figure 7.2 Perpendicular overhead view of a railcar .....	77
Figure 7.3 Angled overhead view of a railcar.....	78
Figure 7.4 Angled side view of railcar.....	79

Figure 7.5 Upward angled side view of railcar representing the optimal angle for viewing ladder, handholds, and the brake wheel.....	80
Figure 7.6 Optimal camera angle relative to the track for the inspection of safety appliances using machine vision technology .....	82
Figure 7.7 Angle representing the physical location of the camera beneath the top of rail.....	82
Figure 7.8 Critical angles in locating the camera for machine vision inspection of safety appliances.....	83
Figure 7.9 Temporary portable field setup for machine vision collection of safety appliance images .....	84
Figure 7.10 Image sequence for one corner of a railcar showing, A) an image taken too early, B) at the optimal time, and C) too late .....	85
Figure 7.11 Three primary steps in the perspective correlation process for an image.....	87
Figure 7.12 Image of railcar after edge detection has taken place.....	88
Figure 7.13 Detection of ladder rungs and handholds on the .....	89
side and end of a railcar .....	89
Figure 7.14 Additional examples of detected ladder rungs and handholds .....	89
Figure 7.15 Brake-wheel detection; yellow indicates no exception and red indicates deformation of the brake-wheel.....	90
Figure 7.16 Plan view showing the camera's field of view and the length of railcar captured during the imaging process .....	91
Figure 7.17 Views of a railcar after deformation was inflicted in a controlled environment (left) and the corresponding 3D model showing the deformation (right).....	94
Figure 7.18 Validation of algorithms on the model image which replicates the deformation seen in the actual image in Figure 7.17 .....	95
Figure 7.19 View of both the BL and AR corners of a covered hopper demonstrating the ease as to which the two opposite corners can be compared.....	99

Figure 7.20 Example images before and after edge detection algorithms were run on the image.....	100
Figure 7.21 Example of overlaid BR and AL corners of a covered hopper car.....	101
Figure 7.22 Average number of visits to WILD sites between October 2004 and November 2005.....	103
Figure 7.23 Car miles traveled by car type in 2004 (AAR 2005).....	105
Figure 8.1 Camera views for interim machine vision installation of railcar safety appliances .....	107
Figure 8.2 View of the BL and AR corners of a hopper demonstrating the ease of comparison of like elements of the safety appliances .....	108
Figure 8.3 View of the BL and AR corners of a hopper showing no deformed safety appliances .....	109
Figure 8.4 View of the BR and AL corners of a hopper.....	110
showing no deformed safety appliances .....	110
Figure 9.1 Images of the brake wheel.....	114
Figure 9.2 Profile view of a common brake wheel design .....	115
Figure 9.3 Brake wheel parameters .....	116
Figure 9.4 Additional brake wheel parameters.....	117
Figure 9.5 Brake wheel viewed from perpendicular to the track showing brake wheel clearance.....	118
Figure 9.6 Brake wheel with insufficient clearance per CFR Part 231 .....	119
Figure 9.7 Example images of the brake step and brake wheel.....	120
Figure 9.8 Brake step parameters.....	121
Figure 9.9 Additional brake step parameters .....	121
Figure 9.10 Image of the brake step taken perpendicular to the tracks and in-line with the brake step .....	122
Figure 9.11 Image of the brake step taken perpendicular to the tracks and above the brake step showing the step's length.....	123
Figure 9.12 End platform on a boxcar showing significant deformation .....	125
Figure 9.13 Sill step without additional rung.....	125
Figure 9.14 Sill step with additional rung.....	126



Figure 9.15 Sill step parameters.....	126
Figure 9.16 Sill step offset underneath the railcar .....	127
Figure 9.17 Sill step viewed from shallow angle to show sill step deformation .....	129
Figure 9.18 Sill step deformation showing an FRA defect (left) and significant deformation (right).....	129
Figure 9.19 Images of the side ladder (left) as well as an image of both the side and end ladders (right) on open-top hopper cars.....	130
Figure 9.20 Design and dynamic parameters for ladders on an open-top hopper car.....	131
Figure 9.21 Additional design and dynamic parameters for ladders on an open-top hopper car .....	132
Figure 9.22 Deformations of side and end ladders on a covered hopper car.....	133
Figure 9.23 Deformations of the top side ladder rung on an open-top hopper car .....	133
Figure 9.24 Side handholds on both the AL and BR corners of open-top hopper cars .....	134
Figure 9.25 Design and dynamic parameters for handholds of open-top hopper cars .....	135
Figure 9.26 Side handhold on an open-top hopper car showing less than the required 2” clearance .....	136
Figure 9.27 Side handholds clearance potentially affected by a piece of coal on an open-top hopper car.....	136
Figure 9.28 View of both the AR and BR corners of the railcar showing the horizontal end handholds on open-top coal cars.....	137
Figure 9.29 Design and dynamic parameters for horizontal end handholds.....	138
Figure 9.30 Additional design and dynamic parameters for horizontal end handholds .....	139
Figure 9.31 Example of an uncoupling lever.....	141
Figure 9.32 design and dynamic parameters for the uncoupling lever .....	142
Figure 9.33 Design and dynamic parameters for end ladder clearance .....	144

## **CHAPTER 1: INTRODUCTION**

### **1.1 Background on Railroad Safety Appliances and Safety Appliance Inspection**

Safe and efficient movement of trains and execution of railroad employee duties are critically important to the railroad industry. Consequently, any method of providing additional productivity, efficiency, and safety benefits is of great interest to railroads. Currently, before a train departs a rail yard it is inspected for a variety of defects, including safety appliance defects. Safety appliances on railcars are the interface between humans and rolling stock with regard to movement of railcars. They consist primarily of handholds, sill steps, brake steps, ladders, running boards, uncoupling levers, and the brake wheel (Figure 1.1).



**Figure 1.1 Picture of the end of a covered hopper car showing the safety appliances: sill step, side and end ladder, brake step, side and end handholds, and the brake wheel**

Safety appliances have been required on railcars since 1893 when Congress passed the Safety Appliance Act (ICC 1893). The Safety Appliance Act focused mostly on the need for automatic couplers and power brakes but also called for what we now consider safety appliances by requiring secure grab irons, or handholds, on cars (ICC 1893, White 1993). The objective was to provide railroad transportation employees with a set of safe, standardized features to mount, dismount, and perform other functions that required them to ride aboard the car. Safety appliances are currently regulated by the Federal Government through the Railroad Safety Appliances Standards, Title 49 Code of Federal Regulations (CFR) Part 231, that specify the location, number, material, and means of securement of all safety appliances (FRA 2004b).

Safety appliances are inspected by railroad carmen primarily using visual cues with some tactile and auditory means occasionally used for certain tasks. Carmen are railroad employees who are trained to inspect cars for many types of defects that may cause the car to be unsafe for movement. In addition to inspection, their duties include repair and re-railing of railcars. Cars are inspected each time they are added to a train, even though they may have satisfactorily passed multiple inspections prior to the current one. Safety appliance inspections occur as a part of more encompassing railroad car inspections. These inspections concentrate on air brakes, the car body, and brake systems among many other mechanical aspects of the railcar. Much of the success of the current inspection process is due to its redundancy. However, carmen inspect hundreds of cars during their shift, and monotony and fatigue may affect the efficiency of inspections.

After carmen complete safety appliance inspections, the results are generally not recorded, thus a railcar's health cannot be tracked over time. This makes both planned

maintenance and monitoring defect trends difficult. Defect trends could be used as a means of locating industries that consistently damage railcars, or be used to suggest future design changes for railcar safety appliances.

Inspections are undertaken while inbound and outbound trains are on receiving and departure tracks. Capacity in yards is increasingly at a premium, therefore improving inspection efficiency also has the potential to increase yard throughput. One way that the effectiveness and efficiency of safety appliance inspections can be increased is through the implementation of machine vision technology. A machine vision system for safety appliance inspection involves capturing digital video of a train as it passes and running machine vision algorithms that identify the safety appliances on railcars and detect defects.

Benefits to a machine vision system would come in several forms. A system of this type would lead to better utilization of labor, more effective inspections, and potentially improve utilization of yard space. The system should be able to categorize defects in terms of the appropriate level of action required. The system would also lend itself to development of a database for each car that would enable trends to be detected and allow better planning and management of railcar maintenance.

## **1.2 History of Railroad Safety Appliances**

In the latter part of the nineteenth century, railroads were considered one of the most hazardous forms of employment (Wetzel 1977). In 1893, the annual fatality rate among all railroad employees was 3.27 per thousand employees (Aldrich 1997). As a means of comparison, bituminous mining had a fatality rate of 2.15 and anthracite mining's fatality rate was 3.00. In a 1913 mortality study investigating the effects of

occupation on mortality it was found that railroad work was more dangerous than most other industries, including mining, with a death rate as much as nine times greater than the average (Medico 1913). Some of the factors contributing to the hazards of railroad work included a general lack of sufficient brakes, too few brakemen, problems with timetable and train order operation, poor infrastructure, and differing operating conditions from railroad to railroad (Aldrich 1997). The first casualty statistics were published by the New York State Railroad Commission in the 1850s documenting the risks to railroad employees, quantifying the number of employees killed, and generally drawing attention to the unsafe conditions of the time (Aldrich 1997). Although there were safer alternatives to the car designs of the day, retrofitting the thousands of railcars would have been costly. As White (2005) put it, retrofitting the railcar fleet would have been more costly than replacing trainmen.

As railroads, governments, and the public became more aware of the safety problem, a group of railroad men, state commissioners, and reformers began to push for the addition of automatic couplers and air brakes on freight cars to curtail the growing number of fatalities and injuries. One of the reformers, Lorenzo S. Coffin, began a fight to make trainmen's jobs safer by speaking to groups of all types, culminating with President Benjamin Harrison (White 2005). Coffin, who was a farmer and part time preacher with no engineering background, changed opinions regarding the high capital costs associated with upgrading railcars by playing on the national conscience (White 2005). On March 2, 1893, on the last day of President Harrison's term, the United States Congress passed the Safety Appliance Act in an effort to curtail the growing number of accidents and fatalities suffered by railroad employees.

The Interstate Commerce Commission (ICC), which had been created six years earlier with responsibility for economic regulation of railroads, now had safety added to its responsibilities. Section 4 of the Safety Appliance Act of 1893 pertains to a subset of what we now know of as safety appliances and stated: “that from and after the first day of July, eighteen hundred and ninety-five, until otherwise ordered by the Interstate Commerce Commission, it shall be unlawful for any railroad company to use any car in interstate commerce that is not provided with secure grab irons or handholds in the ends and sides of each car for greater security to men in coupling and uncoupling cars.” The objective of the Safety Appliance Act of 1893 was to provide railroad transportation employees with a set of safe, standardized features to mount, dismount and perform other functions during transportation. The Safety Appliance Act of 1893 went beyond what we consider safety appliances today by calling for automatic couplers, power brakes, and other devices that would improve the safety of train make-up and operation for the benefit of both employees and passengers. The act did not, however, specify the exact parameters for safety appliances or their installation on the car body.

The ICC conducted safety appliance inspections with the primary goal of identifying defective appliances covered by the law including; couplers, air brakes, draw bar heights, and grab irons (Wetzel 1977). The 1909 report of the ICC noted that the law is “too limited in its scope to afford the full measure of protection to which railroad employees are entitled” (ICC 1909). By 1909, inspectors began reporting defects on appliances other than those included under the 1893 act, including ladders, roof hand holds, hand brakes, running boards, and sill steps (ICC 1909). The ICC had no enforcement power over these additional appliances and could not penalize the railroads

for the using these appliances in a defective condition. At the time, the Masters Car Builders Association (MCBA) maintained standard locations and forms of application for all safety appliances regardless of whether or not they were covered under the law. The MCBA was primarily comprised of mid-level railroad managers who were in charge of the design, purchase, and repair of railcars (White 2005). Allowances for optional methods of application of the MCBA standards were permitted and resulted in confusion which “has been disastrous to hundreds of switchmen and other railroad employees” (ICC 1909).

Even though the additional appliances were not covered under the law, their condition was mentioned in the ICC Chief Safety Appliance Inspector’s annual report (ICC 1909, Wetzel 1977). The additional defect information on the appliances not covered under the law provided needed data to propose additional safety appliance legislation. The 1909 Report of the ICC refers to the omission of these additional appliances from the original law as a “defect” because “the additional appliances are vitally necessary for the safety of employees.”

A bill that included the additional appliances (H.R. 26725) was passed by the Senate in 1909 but failed to be reported in the Senate due to expiration of the session (ICC 1909). The 1909 ICC report goes on to say that the bill “in no way advanced the interest of any inventor or proprietor of a specific device” hinting that Congress may have been skeptical of the bill’s intentions. The ICC (1909) notes the necessity of having uniform equipment by saying that “it is of vital importance to employees that the appliances designed for their safety shall be placed alike on all cars of the same class, so that they may know with certainty, day or night, that they [trainmen] will always find

them in like positions and locations.” The 1909 ICC Report also notes that uniformity was not achieved through voluntary actions of those who are responsible for the railcars and the enforcement issue should be handled in the same manner as couplers, grab irons, and power brakes – through an act of Congress.

On April 14, 1910 an act, hereafter referred to as the Safety Appliance Act of 1910, was passed requiring the number, dimensions, location, and manner of application for safety appliances to be specified within six months for all safety appliances that were named in both the 1893 and 1910 Acts with the objective of further decreasing the number of injuries and fatalities of railroad workers (ICC 1910). This expanded group of appliances included grab irons, ladders, sill steps, hand brakes, running boards, and other similar equipment. In 1910, a joint committee representing the ICC, railroad employees, and carriers met and agreed on safety appliance regulations. These regulations were adopted on October 13, 1910 and served as the basis for the FRA regulations of today (ICC 1910, FRA 2004a). By the terms of the Safety Appliance Act of 1910, the recommendations were made standards for future observance (ICC 1910). The final date of compliance for the Act of 1910 was set at July 1, 1911, a date which is still referenced in today’s Railroad Safety Appliance Standards exempting certain cars built prior to this date from certain sections of the Standards.

In understanding the overall scope of the Safety Appliance Acts it is interesting to note a change in the ICC’s view of providing uniformity of safety appliances. At the time of the Safety Appliance Act of 1893, the majority of ICC’s concern was focused on power brakes and automatic couplers, with only a section of the Act being dedicated to what we refer to today as safety appliances. By 1910 and 1911, the primary focus of the



ICC was the regulation of safety appliances as we now know them, with little mention in the annual reports of those other appliances mentioned in the 1893 Act. Consequently, the Acts and amendments of the time reflected this change.

Paralleling to the acts regulating safety appliances, railroads themselves began to give safety greater importance as they came to recognize the implications of their numerous incidents. In 1910, Ralph C. Richards of the Chicago and North Western (C&NW) Railroad established the first railway safety organization (Aldrich 1992). Richards was the general claims agent for the railroad, was familiar with accident statistics, and was consequently appalled by the carnage of the day (Aldrich 1997).

Within two years of the inception of C&NW's Safety First program, 40% of American railroads had some type of safety organization according to the Central Safety Committee of the C&NW Railroad. The reasoning behind this rapid conversion was twofold; the fact that the initial effort by Richards at the C&NW gained a great deal of positive public attention, and the fact that employers began to be liable for a greater number of their employee's injuries (Aldrich 1997). The 1908 Congress had changed the Employer's Liability Law that governed workers in interstate commerce by abolishing the "fellow-servant" and "assumption-of-risk" defenses that had previously provided protection to employers from liability associated with on-the-job injuries (Aldrich 1997). Aldrich (1997) also notes that the unions began to use the mounting number of casualties as a method of bargaining for wage increases resulting in railroad management seeing the need for improved workplace safety.

In general, many aspects of the original Railroad Safety Appliance Act have evolved into what is today known as The Railroad Safety Appliance Standards, which are

a part of the Federal Railroad Administration's (FRA) Mechanical Standards. In 1967, the FRA was created as a part of the newly formed U.S. Department of Transportation (US DOT) and issued the current Railroad Safety Appliance Standards one year later using the ICC orders of 1911 as a base (FRA 2004a). The last major modification of the standards occurred in 1976 with the addition of two sections (§231.29 and §231.30) relating to locomotives (FRA 2004a). As of 2005, there is ongoing work to update certain sections of the Safety Appliance Standards pertaining to newer car types.

With the passage of the Federal Railroad Safety Act in 1970, the ICC's authority was transferred to the US DOT giving the secretary of transportation broad and general regulatory powers over railroad safety (FRA 2001). This responsibility was delegated to the FRA soon thereafter. Throughout this thesis the terms Title 49 CFR Part 231, 49 CFR Part 231, CFR Part 231, Part 231, and The Safety Appliance Standards will refer to The Railroad Safety Appliance Standards.

## **CHAPTER 2: QUANTIFICATION OF APPLIANCE DEFECT TYPES AND OCCURANCE**

### **2.1 Quantification Methods**

I used two primary sources of data to quantify the occurrence of safety appliance defects; data from FRA safety appliance inspections and Class I railroad bad order data. Additionally, car repair data from the Association of American Railroads (AAR) were used to estimate the magnitude of costs associated with safety appliance repairs. Data from the FRA casualty and accident databases and information from the Switching Operations Fatality Analysis (SOFA) Working Group were analyzed to understand how many injuries and fatalities occur as a result of defective safety appliances. These data served to answer several questions regarding the scope of safety appliance inspections and the impact of safety appliance defects that escape detection. Some of the questions addressed were:

- What is the percentage of cars inspected by FRA mechanical inspectors reported to have defective safety appliances?
- What percentage of cars inspected by railroads are bad ordered due to safety appliance defects?
- What is the percentage of cars inspected by railroads that have safety appliance defects that are repairable in the yard without necessitating a bad order?
- How does the number of safety appliance bad orders vary between yards?
- How much money is spent by North American railroads on safety appliance inspections?

- How much money is spent by North American railroads on safety appliance repairs on cars in interchange service?
- How many fatalities and injuries are suffered by railroad employees as a result of defective safety appliances?
- What is the opportunity cost associated with railcars being out of service for safety appliance bad orders?

These questions and others will be addressed in this chapter.

## **2.2 FRA Inspection Database**

The FRA maintains a database of all inspections conducted by both federal and state inspectors. The data are grouped by specific part of the CFR and also by type of inspector; state or local. The data for Part 231 are divided into major rules. Generally, each major rule pertains to a specific safety appliance. In the case of ladder treads and handholds, as many as four separate safety appliances are covered by one major rule. Other appliances, such as the hand brake, are separated into three major rules. Analysis of these data for the period 1995-2004 showed that 59% of defects occurred on ladder treads, handholds, and sill steps (FRA 2005, Figure 2.1).

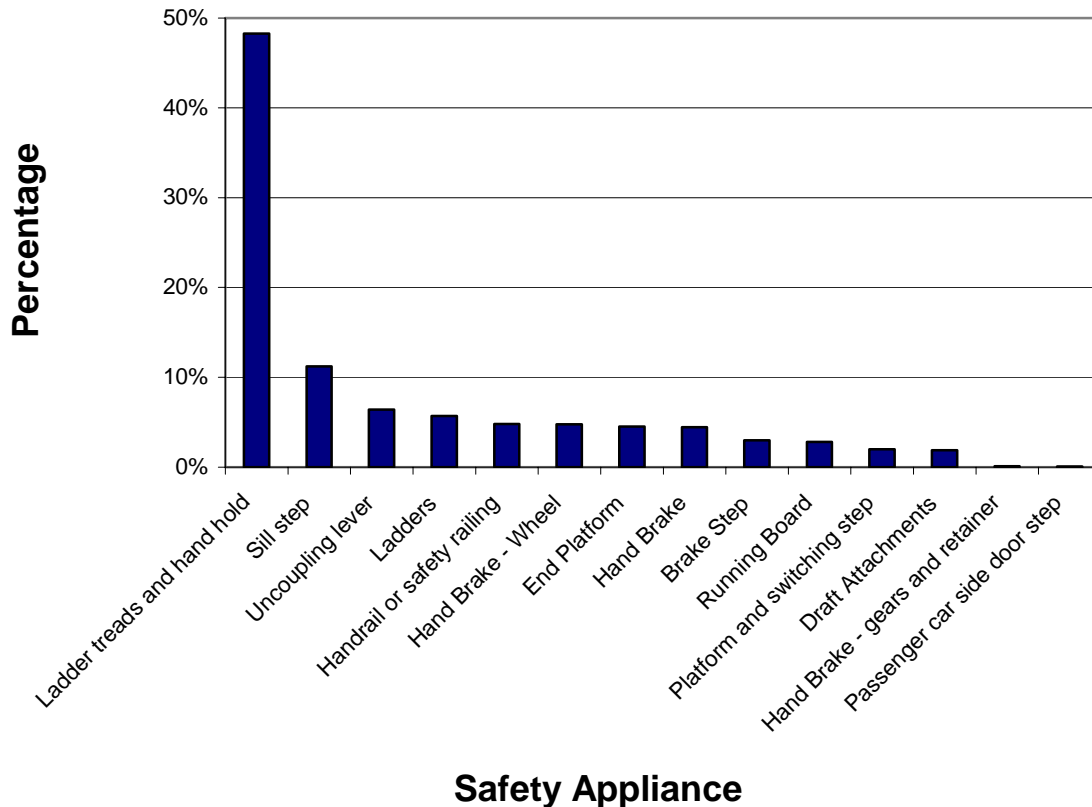

**Figure 2.1 FRA safety appliance defects found by FRA inspectors between 1995 and 2004 grouped by major rule of CFR Part 231**

Between 1995 and 2003, 21% of Motive Power and Equipment (MP&E) inspections focused on the safety appliances and accounted for 32% of the total defects detected by MP&E inspectors. The defect rate, or percentage of defective units (railcars) relative to the number of units inspected, is also given in the FRA database. The rate varies from 5.4% to 7.4% for the years 1995-2004, averaging 6.6% (Figure 2.2). The rate represents the number of defective railcars as a percentage of the total number of units inspected and thus does not reflect multiple defects on a single car. For example, FRA inspectors would flag approximately six cars of a 100-car train for defective safety appliances, with each car having at least one defective appliance on it. These data are important for comparing the difference between the rate that FRA inspectors find safety

appliance defects during MP&E inspections and the rate that railroads find safety appliance defects while conducting car inspections.

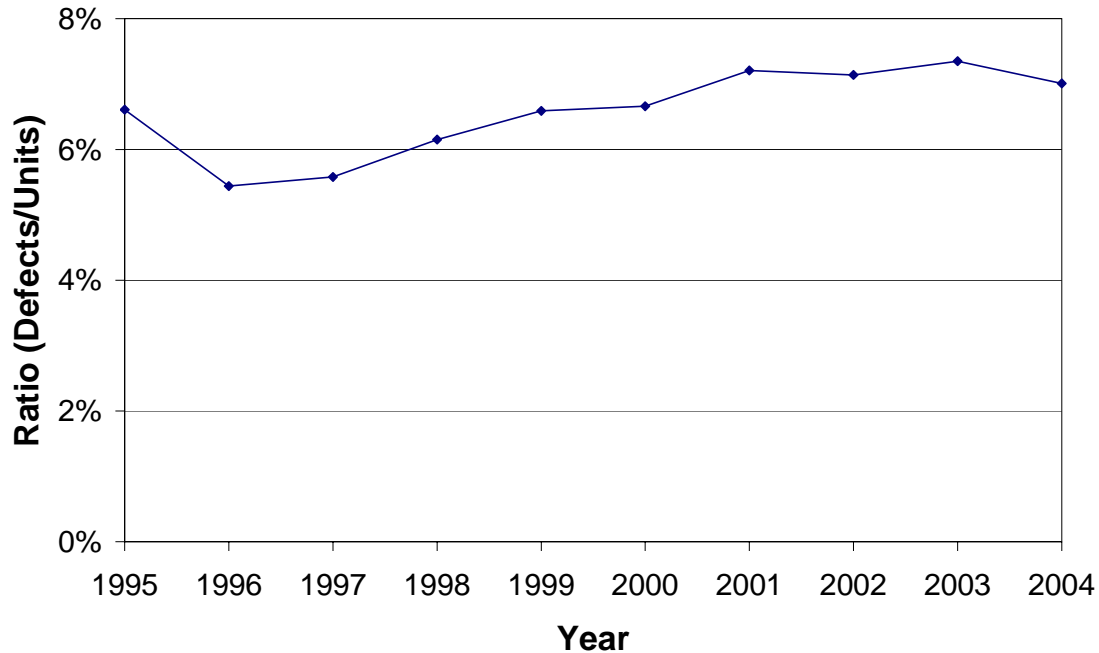

**Figure 2.2 Safety appliance defect ratios from FRA safety appliance inspections for the ten year period of 1995-2004**

### **2.3 Class I Railroad Bad Order Data**

In order to determine the number of defects found by railroad carmen, an initial analysis of bad order data was conducted for the fourth quarter of 2004 at two major Class I railroad yards. According to one major North American railroad 2.5% of cars are bad ordered due to mechanical defects during inbound car inspections. A large percentage of these bad orders are related to the train's brake system. Estimates from mechanical personnel at a major western railroad place nearly 60% of bad orders in this category. Safety-appliance-related bad orders make up approximately 10-25% of all bad orders based on two Class I railroad estimates. Taken as a whole, the percentage of cars

bad ordered due to safety appliance defects was 0.30% and 0.85 % at the two Class I rail yards initially studied in this project.

When calculating this percentage it is difficult to determine the denominator representing the total number of cars that received safety appliance inspections. This is because safety appliance defects are most likely to be found in a subset of inspection types although they should be inspected during all railcar inspections per the Safety Appliance Statute (see Statutory Requirements in Chapter 3). In the case of this analysis I used only inbound inspections and air brake inspection car count numbers in the denominator of the bad order rate since these are generally the inspections in which safety appliance defects are the most likely to be identified. Other types of inspections such as roll-by inspections and the lacing and bleeding of the train's air line were excluded from the calculation.

These safety appliance bad order numbers underestimate the actual occurrence of defects because many cars are repaired in the yard without moving the car to the repair track or facility. These repairs, called "Yard Repairs", are repairs that are carried out by carmen without the car being sent to the repair track and involve the use of graduated pry bars and sometimes acetylene torches. One Class I railroad mechanical manager estimated that as many as 75% of the safety appliance repairs were completed in this way. In these cases there is no requirement to record the repair. One Class I railroad chooses to report these repairs to an in-house database that includes non-AAR billable repairs. If 0.30% to 0.85% of cars are bad ordered for safety appliance defects, and only 25% of safety appliance defects are actually bad ordered to the shop or repair facility, the percentage of cars with safety appliance defects could be as much as four times higher

than the bad order numbers indicate. This would result in 1.2% to 3.4% of cars having safety appliance defects, a figure somewhat closer to the FRA average of 6.6%.

In addition, the differences between the FRA defect rates and the railroad bad order rates are the result of differing amounts of inspection scrutiny. FRA inspectors spend considerably more time inspecting a railcar than do railroad carmen. They may climb on and over a car, checking all the handholds and running boards, whereas railroad carmen are not expected to, nor do they have time to, conduct such an intensive inspection on a routine car inspection. The differences in percentage of safety appliance defects between FRA and railroad car inspections are broken down by appliance in Figure 2.3.

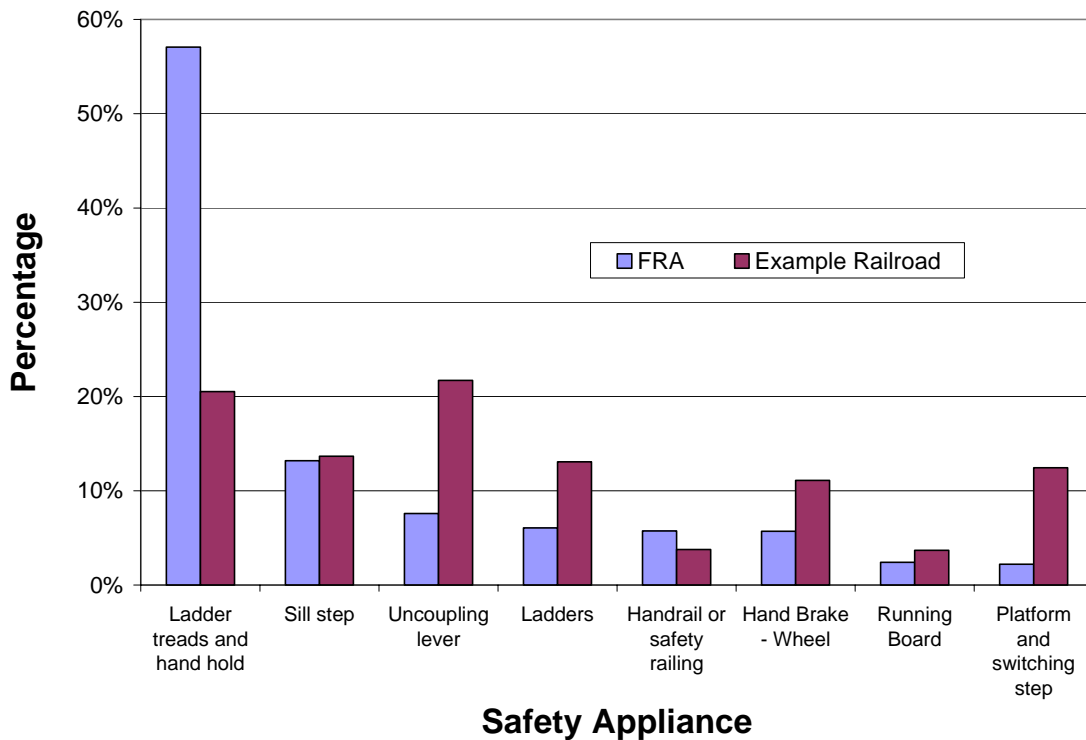

**Figure 2.3 Comparisons of FRA and Class 1 railroad safety appliance defects by car type**



Interestingly, there are considerable differences between the distributions of safety appliances defects in the two yards (Figure 2.4). In Yard A there are more sill steps and operating lever defects whereas in Yard B over 35% of the defects are found on crossover steps alone. According to management at one Class I railroad, the percentage of safety appliance defects is affected by the amount of interchange traffic (Hoyt 2004, Smith 2004). Another cause of the inter-yard variability in safety appliance defects is the differing distribution of car types due to different yard and traffic make-up (Smith 2004, Ameen 2006).

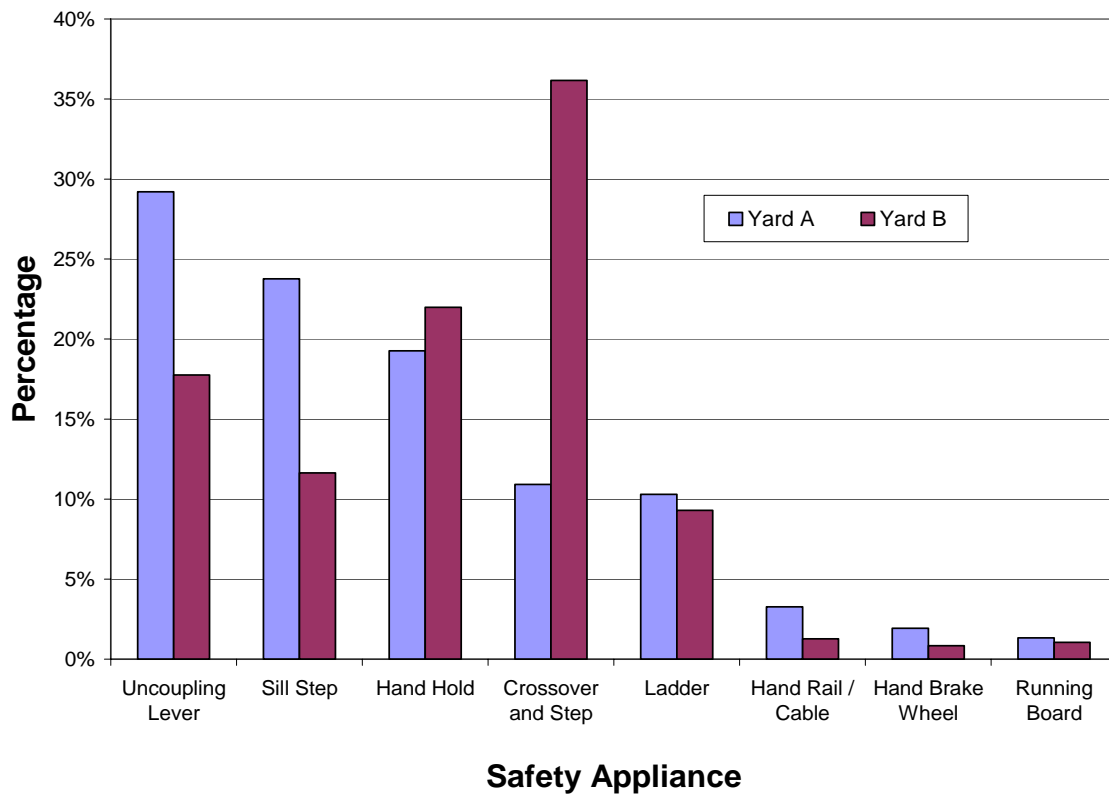

**Figure 2.4 Comparison of safety appliance defects at two Class 1 railroad yards**

Additional analysis of one Class I railroad was undertaken to determine the amount of inter-yard variability in safety appliance bad orders rates. Data were obtained

for October and November of 2005 for each location in which cars were reported to the railroad's mechanical inspection database as being inspected. Locations in which fewer than 1,000 cars were inspected during the two-month period were omitted from the analysis because the average number of cars inspected at all the locations was 29,000 and locations with fewer than 1,000 railcars inspected in a two-month period are likely representative of a location that does not specialize in regular inspection of railcars. The data from the two-month period consists of 2.38 million car inspections and the resulting 5,216 mechanical bad orders from a total of 60 locations on the railroad. The safety appliance bad order rates ranged from 0.018% to 1.779% at each yard with an average rate of 0.269% and a median rate of 0.178% (Figure 2.5).

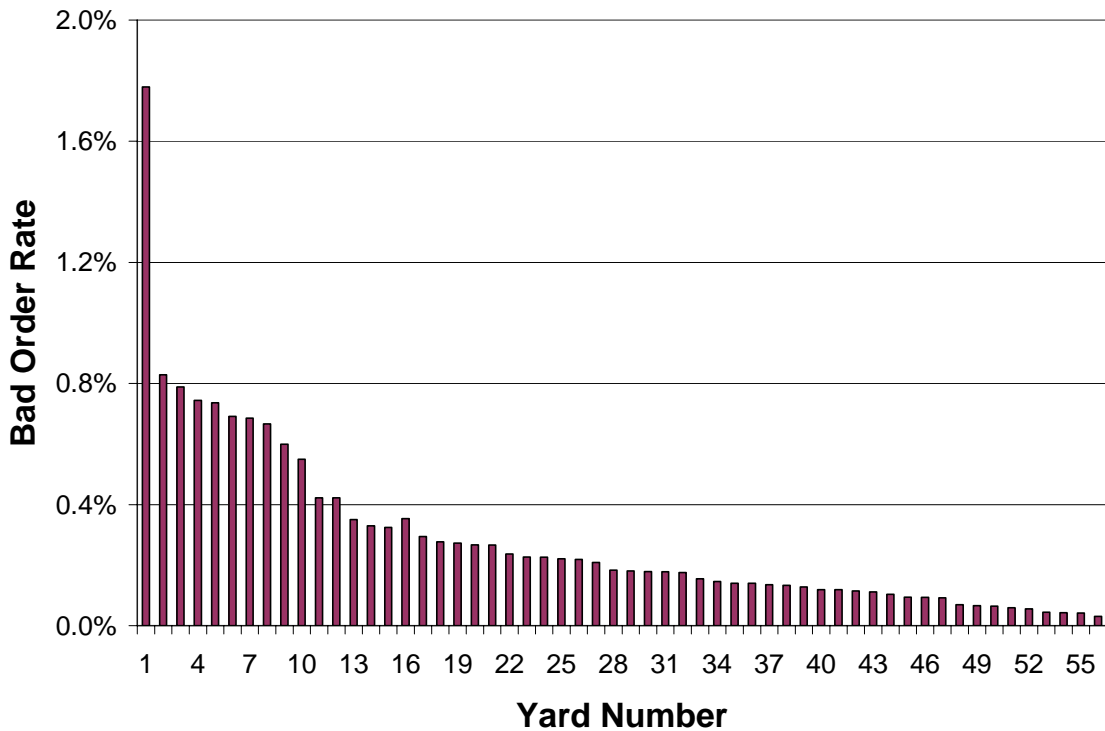

**Figure 2.5 Distribution of safety appliance bad order rates at 60 locations on one Class I railroad**

Using the estimate that only 25% of safety appliance defects result in the bad ordering of the car, the number of cars with defective safety appliances is 1.076%. All but one of the 60 locations has a bad order rate of less than 1.0% (Figure 2.5).

The relative frequency of safety appliance bad orders is also of interest (Figure 2.6, Table 2.1). The greatest percentage of safety appliance bad orders (21.7%) occurred on the uncoupling lever and the fewest (1.0%) occurred on the hand brake wheel.

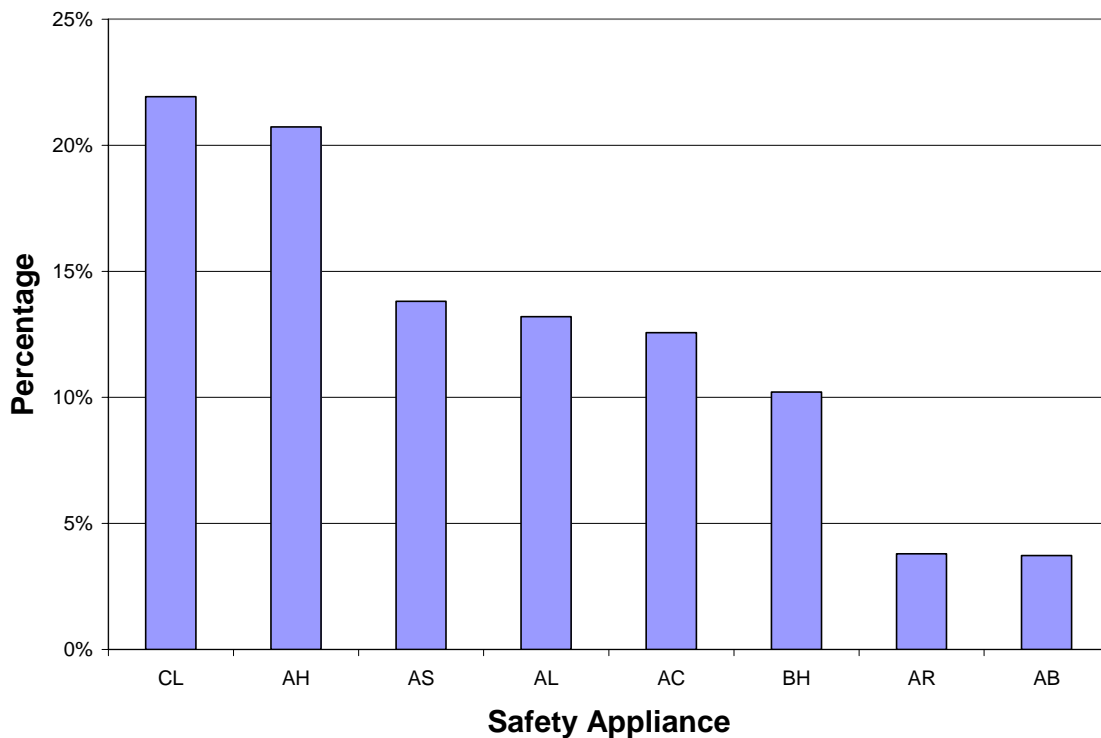

**Figure 2.6 Specific appliances bad ordered on one Class I railroad during October and November of 2005**

<b>Safety Appliance</b>	<b>Bad Order Symbol</b>
Ladder	AL
Sill Step	AS
Hand Hold	AH
Hand Rail / Cable	AR
Running Board	AB
Crossover and Step	AC
Hand Brake Wheel	BW
Uncoupling Lever	CL

**Table 2.1 Safety appliance bad order symbols for one Class I railroad**

## **2.4 AAR Repair Data**

AAR repair data were analyzed to determine the monetary value of safety appliance repairs. In 2003, there were 195,242 repairs reported to AAR on ladders, handholds, brake wheels, and uncoupling levers (AAR 2003a). This represents \$5,177,415 in repair costs billed to railroads and private car owners, or 1.35% of all repairs made in interchange (AAR 2003a). This number substantially understates the total cost of repairs made to safety appliances for several reasons. As mentioned above, most such repairs are made, without a car being sent to a mechanical shop or repair track.

Additionally, the only repairs that are reflected in interchange data are those that occur on railroad-owned cars that are on another (foreign) railroad's property. Even if a car is sent to a repair facility, a safety appliance repair is not billable under the AAR Interchange Rules unless the safety appliance is replaced or removed for straightening (AAR 2004). For instance, if a car is found to have a ladder rung not meeting the clearance requirement of 49 CFR Part 231, the car will be bad ordered. The car will then be repaired per the AAR's Interchange Rules which, under Rule 79, state that no repairs consisting of tightening or straightening are billable.

According to mechanical personnel at one Class I railroad, tightening and straightening of handholds and ladder rungs represents a large number of repairs made by railroads. In conclusion, AAR car-repair billing data may not reflect the full scope of safety appliance defects as well as FRA and railroad safety appliance inspection data.

## **2.5 FRA Casualty Database**

The FRA maintains an extensive casualty database; however, correlating casualties to Safety Appliance violations is nontrivial. Casualties are reported using the Railroad Injury and Illness Summary form (Form 6180.55a). Of all the fields on the form only those relating to activities, locations, and cause of the incident aid in correlating a safety appliance defect to a casualty.

Of the physical act circumstance codes describing the employee's action when they were hurt, eleven of them could be related to safety appliances. Examples would be "getting on", "getting off", "applying handbrakes", etc. Three location fields are listed that refer to the "general location of the person at time of injury", "type of on-track equipment", and the "specific location of person at time of injury". Of the three, only the "specific location of the person at time of injury" can aid in pointing the casualty to a safety appliance defect, as the other two location fields are too broad because safety appliance casualties can occur on most types of equipment in most "general" railroad locations. In addition, codes must be selected to describe the "circumstance of the event", the "tools or objects involved", and the "probable reason for the injury".

In an attempt to link casualties to safety appliance defects, data from the period of 1999-2004 were analyzed. Prior to 1998 there are gaps in the data that do not allow for a complete analysis of casualties associated with the safety appliances of a railcar. In

evaluating the number of incidents in which the codes can be traced to safety appliances, only 19 of the 87 (22%) reports of casualty contained narrative fields that were filled out making it difficult to draw any conclusions. Narrative fields provide descriptions of the incidents and include information obtained by FRA inspectors from railroad employees. An example narrative describing a 1998 incident is as follows; “dismounting car when lower ladder rung gave way, causing him to lose grip falling to ground on tailbone”.

Many of the injuries occurred when a handhold or sill step gave out while an employee was mounting a car. While these injuries occurred on a safety appliance, oftentimes there is no mention within the narrative fields that the safety appliance was actually defective at the time of injury. However, it seems likely that incidents in which the appliance actually failed indicate an appliance that was probably not “securely fastened” which is a violation of the regulations. Overall, the data in the casualty database are not detailed enough to draw a correlation between safety appliance defects and casualties.

## **2.6 FRA Accident Database**

The FRA maintains an extensive database on all railroad accidents that result in damage over a certain monetary threshold. After identifying variables that relate to safety appliances and evaluating the data, I determined that none of the accidents could be correlated to defective safety appliances. There is a possibility that coupler mismatch derailments may occur as a result of incorrect drawbar height, but these derailments seem to be caused by many other contributing factors.

## **2.7 Switching Operations Fatality Analysis Data**

The Switching Operations Fatality Analysis Working Group (SWG) concentrates on understanding past fatalities and severe injuries that occurred during switching operations with the objective of preventing future casualties (SOFA 2004). It includes representatives from FRA, American Short Line and Regional Railroad Association (ASLRRA), AAR, Brotherhood of Locomotive Engineers and Trainmen (BLET), the United Transportation Union (UTU), and Volpe National Transportation System Center (VNTSC). The SWG defines ‘severe injuries’ as injuries that are (1) potentially life threatening; (2) having a high likelihood of permanent loss of function; (3) likely to result in significant work restrictions; and (4) caused by a high-energy impact to the human body.

The SWG has made five operating recommendations that are associated with many fatalities and severe injuries with the objective of preventing future fatalities. These recommendations, known as SOFA’s Five Lifesavers, are summarized in the following manner; (1) secure equipment before action is taken; (2) protect employees against moving equipment; (3) discuss safety at the beginning of a job or when a project changes; (4) communicate before action is taken; and (5) mentor less-experienced employees to perform service safely (SOFA 2004). To make these recommendations the SWG has used FRA narrative descriptions of each fatality as well as other narratives from the railroads to aid in the review of each fatal incident and its circumstances. Unfortunately, the FRA injury forms do not require enough information to fully understand the causes of injuries. Narrative fields are only fully completed when a

fatality occurs, whereas the completion of narratives is scattered at best when casualties are reported.

To date, the SOFA working group has analyzed one hundred twenty five switching fatalities occurring during the period of January 1992 through December 2003 (SOFA 2004). The SOFA working group did not conclude that safety appliance damage was a factor in any of these switching injuries and fatalities (Browder 2005). There were, however, two instances of fatalities that occurred on railcar safety appliances during the ten year period.

One incident occurred on the Montana Rail Link at Laurel, Montana in 1997 and involved a switchman that fell off a car while attempting to board it to set the hand brake. The car was found to have a brake platform that was 2” under the FRA mandated width for 30” of the brake step. The SWG report makes no mention of whether or not the FRA took exception to the defective brake step and the SWG does not mention equipment as being the cause of the incident. The employee involved in the incident had 10 months experience and the SOFA working group suggested that one of their five lifesavers, mentoring less experienced employees, could have prevented the incident. The brake step that was less than the FRA required width was unlikely to have been bad ordered by a railroad or cited by the FRA as having a defect. This is because FRA inspectors will generally not flag cars that have performed safely for many years but were constructed with appliances that are not in compliance with CFR Part 231.

The second incident occurred on Conrail in Indianapolis, Indiana in 1995 and involved a conductor falling off a car during a switching operation. The FRA took



exception to the lack of a BR end handhold that could have been used to aid the conductor in his movement from the side of the car to the end of the car.

Although the report does not make mention of it, a member of the SOFA working group stated that the cars in both of the above incidents may have been identified as having safety appliance defects, but were in the process of being moved to a repair facility when the incidents occurred. In general the SWG did not identify safety appliance damage as a significant issue with respect to switching operations fatalities and casualties (Browder 2005).

## **2.8 Opportunity Costs Due to Cars Being Out of Service**

The cost of having railcars out of service for safety appliance bad orders should be considered when evaluating the total costs of safety appliance defects. Cars are taken out of service an average of 48 hours when they are bad ordered according to one Class I railroad. The North American railcar fleet must be incrementally larger to account for the periods of time when cars are out of service. Reductions of this time out of service are possible through modifications to the current car inspection and repair procedures.

Railcars are worth between \$50,000 and \$100,000 and their average life is approximately 30 to 40 years. In 2003, there were 1.3 million railcars in service in North America (AAR 2003). If approximately 2.5% of cars are bad ordered each time they are inspected that indicates that roughly 32,500 are out of service for this reason at any point in time. At most, 25% (or 8,125) of these cars are bad ordered due to safety appliance bad orders. This suggests that the fleet must be this much larger and that \$400 million in capital is tied up in safety appliance bad orders at any given time.

## 2.9 Summary of Safety Appliance Data

Table 2.2 shows the answers associated with the questions posed at the beginning of this chapter. It is important to note that safety appliance inspections occur as a part of many other types of inspection, thus getting definitive cost figures pertaining to safety appliance inspections is difficult. The ability to link safety appliance defects with fatalities and injuries is not presently available due to the lack of completed narrative fields in the FRA database. There is a large difference between the percentage of defective safety appliances found by FRA inspectors and the number of Class I railroad safety appliance bad orders but the difference is explained through information gained in interviews with Class I railroad mechanical management.

<b>Question</b>	<b>Answer</b>
What is the percentage of cars inspected by FRA mechanical inspectors reported to have defective safety appliances?	An average of 6.6%
What percentage of cars inspected by railroads are bad ordered due to safety appliance defects?	Between 0.30% and 0.85%
What is the percentage of cars inspected by railroads that have safety appliance defects that are repairable in the yard without necessitating a bad order?	Up to 75% according to two Class I railroads
How does the number of safety appliance bad orders vary between yards?	Considerably, due to differing amounts of interchange traffic and differing yard and traffic make-up
How much money is spent by North American railroads on safety appliance inspections?	The cost of inbound car inspections is \$15-20 million annually and \$270 million annually is associated with air brake inspections (2001 AAR data)
How much money is spent by North American railroads on safety appliance repairs on cars in interchange service?	\$5,177,415 during 2003
How many fatalities and injuries are suffered by railroad employees as a result of defective safety appliances?	Probably few but difficult to quantify, more data are needed
What is the opportunity cost associated with railcars being out of service for safety appliance bad orders?	Approximately \$400 million in capital due to an incrementally larger railcar fleet

**Table 2.2 Summary of Safety Appliance Defect Data**

## **CHAPTER 3: RAILROAD CAR INSPECTIONS**

### **3.1 Introduction**

Railcars are inspected for various reasons prior to departing a yard. These inspections are intended to ensure that they are safe for operation and the execution of railroad employee duties. US federal regulations specify many of the inspection types and in some cases the frequencies (FRA 2004b). While the inspection parameters are strict, the time at which inspections must be made is flexible in some cases, thus the point in the yard at which cars are inspected varies among railroads. In this chapter I discuss the various types of inspections, as well as parameters, frequencies, and methods of performing these inspections. The FRA published a guide known as the Motive Power and Equipment Compliance Manual that provides guidance to both Federal and State inspectors with the goal of insuring uniformity of compliance between inspectors (FRA 2004a).

### **3.2 Car Inspectors**

The FRA Railroad Freight Car Safety Standards state that railroads, at certain locations, must have personnel on hand capable of inspecting freight cars (FRA 2004b). These personnel who carry out railroad car inspections are known as carmen and are a unionized group under the Brotherhood Railway Carmen (BRC) division of the Transportation Communications Union (TCU). Before becoming an FRA designated inspector, carman must go through an extensive apprenticeship program lasting anywhere from six months to two years in which they are trained to inspect cars for various

mechanical defects including worn brake shoes, air brake defects, safety appliance defects, car body defects, as well as others railcar defects that could cause a railcar to be unsafe for movement (Smith 2004).

Additionally, the inspectors must be capable of making determinations of whether or not a defective car can be safely moved to a repair facility or whether it should be repaired in place. Carmen also perform other tasks in addition to inspecting railcars including repairing, overhauling, and re-railing them. At times, train and engine (T&E) crew personnel act as car inspectors when designated mechanical inspectors are not on duty.

### **3.3 Inspection Duration**

Inspection duration is closely related to inspection cost. Inspection duration must be understood in order to quantify some of the potential benefits of partial automation of car inspection. This section contains information on Class I railroad car inspection times as well as inspection duration data from a FRA classification yard model. It is difficult to determine the exact times needed to perform inspections, since inspections can vary from railroad to railroad in terms of scope, even though all satisfy the FRA regulations.

#### *3.3.1 FRA Estimate of Inbound Inspection Duration*

In 1981, the FRA published a Railroad Classification Yard Technology manual with the objective of improving the engineering and design of classifications yards to increase the efficiency of the yard design process (FRA 1981). As a part of the manual the FRA developed a receiving yard simulation model containing a formula for the time associated with the inbound inspection of a train.

$$TI = NC/RI + IC$$

Where;

TI = inbound inspection time interval

NC = number of cars in each train

RI = rate of inbound inspection

IC = inbound inspection constant

This equation takes into consideration the time required for the crew to inspect the train, time to do paperwork, and other delays but does not reflect the number of carmen used to inspect a train. The FRA manual recommends a value of five minutes for the inbound inspection constant, representing paperwork and other delays, and an inspection rate of two cars per minute. The manual also makes the assumption that inspection starts immediately after a train arrives if an inspection crew is available. This assumption does not necessarily reflect typical railroad operations, but provides an estimate of the inspection time starting from the point at which an inspector is available to inspect a train.

Using the aforementioned constants, the inspection time for a single carman inspecting a 100-car train would be 55 minutes. Taking into consideration that more than one inspector may work a given train, we can state more generally that a 100-car train can be inspected in 55 person-minutes where one person-minute equals one minute of a person's time. In general, anywhere from one to four carmen are used to inspect trains. Each additional carmen reduces the total amount of time needed for a train's inspection, thus getting the train out of the yard sooner – if other factors are in place. These factors

include the availability of crews, the capacity on the line, and the lack of any mechanical defects in the consist.

### *3.3.2 Class I Railroad Estimate of Inspection Duration*

One major North American railroad uses two minutes, or 60 seconds per side of car, as the time needed to perform an inbound inspection on a railcar. This rate is four times longer than the FRA estimate thus four times as many inspectors must be used per 100 car train to equal the total inspection time of 55 minutes.

### *3.3.3 AAR Estimate of Inspection Duration*

Based on data representing all Class I railroads, air brake inspections require an average of two-person minutes per car, including the time needed to give the train blue flag protection before inspection can begin. Inbound car inspections, or the complete pre-departure inspection, are estimated at 1.5 person-minutes per side of car, or 3 person-minutes per car.

### *3.3.4 Summary of Inspection Duration Estimates*

The inspection rate from the example Class I railroad is two minutes per car or one-half of a car per minute. The FRA inspection rate is two cars per minute, or four times greater than the Class I inspection rate. The inspection rate obtained from the AAR is the lowest of the three at three minutes per car, and requires 50% more time than the Class I inspection time. Regardless of inspection rate, a carman may inspect hundreds of cars per shift resulting in a monotonous task.

### **3.4 Inspection Cost**

Based on 2001 data compiled by AAR to estimate inspection costs, annual labor costs for inbound car inspections at Class I railroads are valued at between \$14 and \$20 million (AAR 2006). In the AAR calculation an inspector hour is valued at \$39.00, considering salary and direct fringe benefits, but no overhead. An additional \$36.5 million is spent in train delay costs due to inspection delay. Train delay costs were estimated using an average expense of \$158 per hour. Another \$270 million is spent in completing both the Initial Terminal and Intermediate Air Tests, which should include safety appliance inspections. This cost for air brake tests includes the costs that are incurred due to train delay as well as the cost of labor.

### **3.5 Regulations Governing the Inspection and Repair of Railcars**

The FRA maintains the standards that govern the inspection of railcars, 49 CFR Part 231. FRA inspectors make unscheduled visits to yards to determine if railroads are operating in accordance with FRA standards. Failure to abide by these standards results in exceptions being assessed by FRA inspectors. Each instance of an exception does not necessarily result in a fine being assessed since inspectors have multiple means of enforcement. Up until 2001 FRA inspectors were required to see a car moved before that car could be taken exception to.

Currently, if the car is placed in an outbound train that has been inspected, FRA inspectors can take exception to the car without the car moving (Carrulo 2005). The FRA Motive Power and Equipment Compliance Manual (2004a) states that the added enforcement flexibility, while available to inspectors, may not be the best means of

issuing a violation and that in many cases the best approach may be to establish movement or use before assessing a violation.

Once cars are determined to be defective per FRA standards they are repaired under the guidance of the AAR Field Manual of the Interchange Rules (AAR 2004). The Field Manual specifies the type and cost of repairs that are billable. For example, if a carman finds a handhold with a clearance less than the FRA mandated 2” minimum, the car must be bad ordered for repair. However, once the car arrives at the shop or expedite track AAR Interchange Rule 79 states that the repair is not billable unless the handhold is missing and has to be replaced or has to be removed to be bent back into shape (AAR 2004). Specifically, Rule 79 states that no labor shall be charged and a billing repair card is not required for the following; 1) handholds, handhold brackets or ladder treads tightened or straightened on the car, 2) ladders and ladder supports tightened or straightened on car, or 3) sill steps, tread, braces or supports tightened or straightened on car. In some cases, such as wheel flange depth, the AAR Rules are more stringent than the FRA standards. In other cases, such as many of those associated with the safety appliance standards, the FRA standards are stricter requiring repair despite the inability to bill for that repair.

There are three parts of the FRA Railroad Mechanical Department Regulations that relate to train inspections. The first, The Freight Car Safety Standards, give guidance as to when cars should be inspected and what aspects of cars should be inspected. Next, The Railroad Safety Appliance Standards set the standards for safety appliances on all rail equipment. Finally, The Brake System Safety Standards defines the manner and frequency in which a train’s air brake system is tested.



### *3.5.1 FRA CFR Part 215 – The Freight Car Safety Standards*

(What follows is an interpretation of 49 CFR Part 215 and closely resembles Part 215)

Part 215 describes the minimum Federal safety standards for railroad freight cars that are in service on any standard gauge railroad. Part 215 requires railroads that have cars to which this part applies to have designated persons qualified to inspect freight cars for compliance with this part. Additionally, these inspectors should be able to make determinations as to whether or not a defective car can be safely moved. Part 215 goes on to define a designated inspector as a person designated under this section who shall have demonstrated the railroad knowledge and ability to inspect railroad freight cars for compliance with the requirements of this part and to make the determinations required by §215.9 of this part. Section 215.9 details the procedure that must be followed in order for a defective car to be moved for repair.

According to §215.13, at each location where a freight car is placed in a train, the car should be inspected prior to the train's departure. This inspection can take place before or after a car is placed in the train, but further details of this inspection are not provided in Part 215. Two Midwestern Class I railroad yards provide further insight into these two different times when cars can be inspected. One flat-switched yard that inspects an average of 800 cars per day inspects cars on the inbound before they are placed in an outbound train. Another yard, a major flat-switched yard that inspects an average of 2,800 cars per day, inspects railcars after they are assembled into an outbound train as a part of the Class I air brake inspection.

If a designated inspector is not on duty or employed at a location where cars are placed in a train, a train must be given an "Appendix D inspection". The inspection parameters of an Appendix D inspection can be found in Appendix D of Part 215 and a

discussion of these conditions can be found below under section 3.8.3, Pre-Departure Inspections.

### *3.5.2 FRA CFR Part 231 – The Railroad Safety Appliance Standards*

The Railroad Safety Appliance Standards govern the use and placement of safety appliances on railcars and are detailed in Chapter 4 of this thesis. The Railroad Safety Appliance Standards do not specify an inspection frequency. This topic is addressed in the section on the Safety Appliance Statute in this chapter. The standards are broken up by car type. If the car in question does not fall under a specific car type, the FRA Motive Power and Equipment Compliance Manual (2004a) requires that railcars comply with the section of The Railroad Safety Appliance Standards that correlates to the “nearest appropriate car type”.

### *3.5.3 FRA CFR Part 232 – Brake System Safety Standards for Freight and Other Non-Passenger Trains and Equipment*

CRF Part 232 prescribes the inspection and testing requirements for freight and non-passenger trains brake systems and equipment. This includes the applicability, training of inspectors, and all inspection and testing requirements for each type of brake test. Part 232 also includes guidance on what constitutes the nearest available location in which mechanical repairs can be made on a railcar (FRA 2004a).

## **3.6 Statutory Requirements for Railcars**

The Railroad Safety Appliance Standards do not directly state the frequency of railcar safety appliance inspection, but there is strict liability associated with the Safety Appliance Standards (Carrulo 2005, Ameen 2006). Although the FRA cannot force the

railroads to inspect cars at a given interval, it is implied that they look at cars each chance they have, regardless of the inspection type. This implied liability is explained through a portion of the transportation statutes relating to railroad safety. Safety Appliances, Part 203, fall under Part B – Safety (U.S. House 2004). Part 203 has three sections that are critical in the understanding of the implications and interpretation of Part 231. These are titled definition and non-application general requirements, moving defective and insecure vehicles needing repairs, and assumption of risk by employees.

The first section, 20301, defines a vehicle as a car, locomotive, tender, or similar vehicle. It also states that these statutes do not apply to 4-wheel coal cars, 8-wheel coal cars under 25” in height, the locomotives used to pull these cars, and equipment used on a street railway. This generally excludes mining and other non-interchange railroads.

Section 20302 sets aside the general requirements. These requirements state that a railroad carrier may use a vehicle only if it is equipped with, among other things secure sill steps and secure ladders and running boards when required by the Secretary of Transportation. It goes on to say that unless otherwise ordered by the secretary it should have secure grab irons or handholds on its end and sides for greater security to individuals in coupling and uncoupling vehicles.

Section 20303 states that “A vehicle that is equipped in compliance with this chapter whose equipment becomes defective or insecure nevertheless may be moved when necessary to make repairs, without a penalty being imposed under section 20302 of this title, from the place at which the defect or insecurity was first discovered to the nearest available place at which the repairs can be made”. This location must be located on the railroad line on which the deficiency was discovered or on a connecting railroad

line if the connecting carrier agrees to accept the car, if the shop is not farther than the place of repair on the initial carrier's line. This location could be opposite the direction that the car was headed. The nearest place at which repairs can be made may be the location where the defect was discovered. This would be the case if the car were inspected at a yard or terminal with a repair facility or if a mobile repair vehicle were assigned to the area in which the defect was discovered. In the latter case, the car would need to be repaired in place.

If repairing in place is not an option, the car can be moved to the nearest repair location as described above. The FRA generally does not require the railroad to transfer the defective car to another carrier if the other carrier's shop is closer to its own (Carrulo 2004). Specifications regarding movement of defective equipment relating to power brakes can be found in §232.15, but these specifications also apply to safety appliance defects according to the FRA Motive Power and Equipment Compliance Manual (2004a).

Railroads may be reluctant to move a vehicle with a defective safety appliance due to the following clause in section 20304: "The movement of a vehicle under this section is at the risk only of the railroad carrier doing the moving. This section does not relieve a carrier from liability in a proceeding to recover damages for death or injury of a railroad employee arising from the movement of a vehicle with equipment that is defective, insecure, or not maintained in compliance with this chapter." One Class I railroad assumes safety appliances should be repaired before a car is moved, regardless of the above provision in section 20304.

### **3.7 Inspection Jurisdiction**

The FRA Yard Worker Safety Report (2001) provides details regarding the jurisdiction of safety regulation within the railroad environment. Unlike many other industries, all aspects of railroad worker safety are not under the jurisdiction of the Occupational Safety and Health Administration (OSHA). In 1970 the Occupational Safety and Health (OSH) Act allowed railroad workers to be regulated by both the Secretary of Labor and the Secretary of Transportation (FRA 2001). The act required employers to improve working conditions to a level free of hazards that could result in death or injury.

These requirements have evolved into an extensive set of standards that are maintained by OSHA, now a part of the Department of Labor (DOL). However, as an alternative to dual regulation by DOT and DOL, Congress included a provision that stated that the OSH Act shall not apply to working conditions where Federal agencies have overlapping authority to prescribe or enforce occupational health and safety standards. Additionally, FRA decided to concentrate its efforts on the traditional areas in which it was most familiar and not to issue any more standards outside of railroad-specific operations. Other than the repair facilities in which safety appliance defects are corrected, OSHA regulations do not apply to work being completed by the majority of railroad employees in the field other than shops, office buildings, and other fixed work places. For instance, when it comes to overseeing a safe means of egress from buildings and equipment the FRA has jurisdiction over rolling stock and OSHA has jurisdiction over fixed facilities. Reports of injuries go directly to FRA and not to OSHA, with some data being reported to OSHA by FRA.

### **3.8 Types of Car Inspections**

There are a variety of types of car inspections and it is important to understand them and the parameters each is intended to address. Safety appliances are inspected as a part of several inspections, but mostly during air brake and pre-departure inspections. While tasks for a given inspection are predominantly the same from railroad to railroad there are differences, primarily in the number of inspectors used and the exact point during yard processing in which the railcar is inspected.

#### *3.8.1 Air Brake Inspections*

##### 3.8.1.1 Class I Brake Test

The Class I brake test is also known as the initial terminal inspection. As defined by the FRA, the initial terminal is the location where a train is originally assembled. This test is completed at the initial terminal or any location where the train was off-air for four or more hours, received in interchange with the consist being broken, or if a unit or cycle train has traveled more than 3,000 miles since its last Class I Brake Test. This inspection consists of checking for brake pipe leakage, ensuring all brakes are applied, released, and all moving parts are functional, brake rigging securely fastened, brakes must be responsive to a 20-psi reduction, and the pressure differential between the locomotive and end of train must be less than 15-psi. Part 232 does not mention the need for inspection of other aspects of the train, as in safety appliances or other mechanical defects, but the inspection of safety appliances is implied under the safety appliances statute.

##### 3.8.1.2 Class IA Brake Test

Class IA brake tests are known as 1,000-mile inspections and consist of checking for functionality of all moving parts, ensuring that the brake rigging is securely fastened,

checking to see if brakes are responsive to a 20-psi reduction, and checking that the pressure differential between the locomotive and end of train is less than 15-psi. These inspections must take place at a distance of less than 1,000 miles from the point where a train last received a Class I or Class IA brake test.

#### 3.8.1.3 Class II Brake Test

Class II Brake Tests are known as intermediate inspections and occur at any location other than the initial terminal of a train. Intermediate inspections consist of leakage tests, the testing of the application of brakes in each car added, and a roll-by inspection to determine that all brakes are released. When a Class II test is performed on a car it is required that a Class I Brake test is performed at the next location where one can be performed.

#### 3.8.1.4 Class III Brake Test

Class III Brake Tests are known as trainline continuity inspections and required for any train that changes its locomotive or switches out a block of cars. The test involves ensuring that the pressure at the end of the train is 60 psi or greater, that the rear car's brakes apply during a 20-psi reduction, and that the brakes release properly afterwards.

### *3.8.2 Inbound Car Inspections*

What follows are guidelines from the Inbound Car Inspection Program, produced by the Railway Educational Bureau (1998). Cars are inspected using the CFR, AAR Interchange Rules, and the individual railroad's practices. Cars are inspected at locations where they are placed in a train and inspected before the train departs or prior to the car being placed in the train. Aspects of cars that are inspected include, but are not limited

to: wheel gauge, roller bearings, bearing adaptors, springs, snubbers, brakes, piston travel, draft system, center and side sills, brake system components, and car bodies. The only portion of this inspection that includes safety appliances is the “car body” portion of inspection. Car inspectors should know the Freight Car Safety Standards (CFR Part 215) and the Power Brake Standards (CFR Part 232) in addition to the Safety Appliance Standards (CFR Part 231). A complete list of defects that should be recognized by car inspectors on inbound inspections is presented in Appendix A.

### *3.8.3 Pre-Departure Inspections*

49 CFR 215 states that freight cars should be inspected at any location where a freight car is placed in a train. This inspection can occur before or after the car is placed in the train, but must take place before the train departs the yard. There are two types of pre-departure inspections, which one occurs is affected by the location of the inspection.

The first type of pre-departure inspection occurs at any location in which a designated inspector is on duty. This will likely be the case at all rail yards except very small ones. This inspection covers other parts of the CFR beyond Part 215 such as Parts 231 and 232 as no inspection parameters are laid out in Part 215.

The second type of pre-departure inspection occurs at locations where cars are added to a train and a designated inspector is not present and shall be conducted according to CFR Part 215, Appendix D. This inspection is conducted by a member of the train crew who will look for, at a minimum, the following defects (FRA 2004b):

1. Car body
  - i. Leaning or listing to side
  - ii. Sagging downward



- iii. Positioned improperly on truck
  - iv. Object dragging below
  - v. Object extending from side
  - vi. Door insecurely attached
  - vii. Broken or missing safety appliance
2. Lading leaking from a placarded hazardous material car
  3. Insecure coupling
  4. Overheated wheel or journal
  5. Broken or extensively cracked wheel
  6. Brake that fails to release
  7. Any other apparent safety hazard likely to cause an accident or casualty before the train arrives at its destination.

This inspection is often referred to as an “Appendix D Inspection”. The seven conditions listed above are considered imminently hazardous, as they are likely to cause an accident or casualty before the train arrives at its destination. These conditions are also considered to be readily discoverable by a train crew member in the course of a customary inspection. In the pre-departure inspection the following two points of inspections relate to safety appliances; looking for a broken or missing safety appliance and any other apparent safety hazard likely to cause an accident or casualty before the train arrives at its destination.

### 3.8.4 Other Inspection Types

Other inspections include roll-by inspections, lacing the train, bleeding the train, and testing the EOT device, and an example of these is explained in the next section.

### 3.9 Sample Inspection Types for one Class I railroad

Table 3.1 provides examples of the various inspection types performed by one Class I railroad.

<b>Inspection Type</b>	<b>Inspection Symbol</b>
Class I Air Test	ABT
Bleed Only	BLD
Combined Air/Standing Inspection	CBT
Standing Inspection	CCI
Lace Only	CPL
Roll-By	RBY
End-Of-Train Device Test	SBU

**Table 3.1 Inspection types and corresponding inspection symbols for an example Class I railroad**

When a train arrives at a yard on this railroad it receives an inbound inspection, which is also known as a standing inspection. This inspection involves bleeding the air in the train line and looking for car body defects including on safety appliances. It is helpful that bad orders are identified at this point in the car's movement through the yard so it can be set out and repaired thereby avoiding delay of the outbound train, and the resultant expense. Another type of inspection is the Class I air test. Lacing the train is considered a part of the inspection. A Class I air test is the pre-departure inspection for an outbound train and was discussed in section 3.8.1.1, "Class I Brake Test". A Class I air test is not specifically used to identify defective safety appliances but since cars are

being inspected by qualified mechanical inspectors, they are required to look for any mechanical defects each time they inspect the cars. If an inspector does find a safety appliance violation on the outbound inspection, it will be flagged and repaired before the car leaves the yard. A third inspection is known as a combined air/standing inspection that is the combination of the previous two.

Which inspection type and how many inspections occur depends on the specific parameters of a given yard. Figure 3.1 shows the differences between the numbers of each type of inspection between two yards at the railroad.

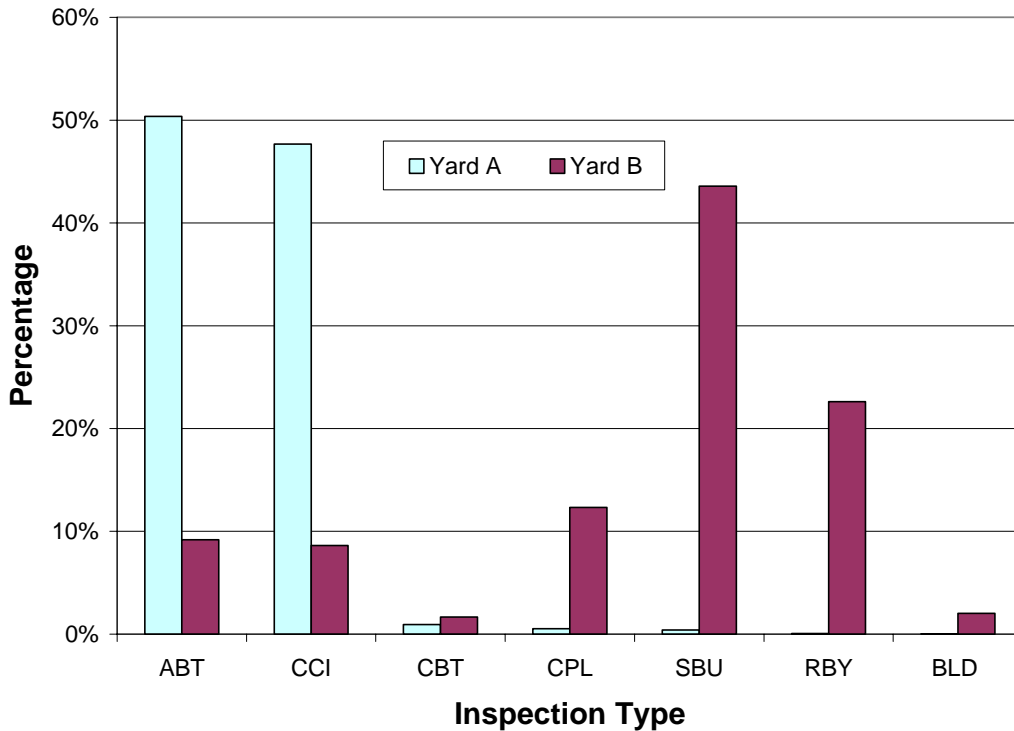

**Figure 3.1 Comparison of the percentage of cars inspected by each inspection type at two Class I railroad yards**

98% of the inspections at Yard A are either inbound inspections or air brake inspections. Yard A sees a substantially lower percentage of safety appliance bad orders. This is counterintuitive given the fact that this yard conducts a much higher percentage of

standing inspections compared to Yard B. The distribution of inspection types at Yard B is more uniform, with the majority being Roll-By or End-of-Train Device inspections.

Additionally, railroads monitor a large number of parameters associated with the inspection of railcars. Table 3.2 contains data pertaining to the inspection of cars at Yard A. As can be seen in the data, the bad order percentage is the highest for standing inspections.

Shift	Inspection Type	Total Number of Trains	Total Number of Cars/ Inspection	Average Number of Cars/Train	Average Dwell Time (Min)	Avg Inspection Time (Min)	Average Wait Time (Min)	Average Minutes / Car (Planned)	Average Minutes / Car (Actual)	Number of B/Os	B/O %
First	ABT	482	29,586	61	27.7	16.1	11.6	2	1.9	86	0.3
	CBT	5	128	26	12.0	4.0	8.0	4	4.0	0	0.0
	CCI	423	21,652	51	35.7	16.9	18.8	2	1.9	391	1.8
	CPL	1	44	44	0.0	0.0	0.0	1	1.0	1	2.3
	SBU	233	233	1	26.3	2.0	24.3	18	17.4	0	0.0
Second	ABT	364	23,714	65	29.3	15.7	13.6	2	2.0	37	0.2
	CBT	14	1,001	72	78.2	19.3	58.9	4	1.9	3	0.3
	CCI	562	28,022	50	22.7	9.9	12.8	2	2.0	289	1.0
	CPL	2	154	77	0.0	0.0	0.0	1	1.0	0	0.0
	SBU	117	117	1	31.8	2.5	29.3	18	16.4	0	0.0
Third	ABT	447	26,783	60	27.2	17.5	9.6	2	2.0	49	0.2
	CBT	9	358	40	0.0	0.0	0.0	4	3.7	2	0.6
	CCI	484	26,134	54	27.1	16.4	10.7	2	1.9	369	1.4
	CPL	9	642	71	17.8	7.8	10.0	1	0.9	3	0.5
	SBU	297	297	1	26.8	2.0	24.8	18	16.9	0	0.0
<b>TOTAL</b>		<b>3,451</b>	<b>158,985</b>	<b>46.0</b>	<b>27.9</b>	<b>12.7</b>	<b>15.2</b>	<b>2.1</b>	<b>2.0</b>	<b>1,189</b>	<b>0.8</b>

**Table 3.2 Data from one Class I railroad yard representing parameters that are monitored with respect to the car inspection process**

### 3.10 Safety Appliance Use

Currently, each railroad has its own procedures regarding use of safety appliances. Some railroads allow their employees to mount and dismount a railcar while it is moving provided they follow specific procedures dictating how to do so safely. Other railroads allow their employees to ride on safety appliances while the car is in motion, but do not allow the employees to mount it while it is moving. Each time a car is to be mounted or dismounted it must be stopped and then restarted after the employee is on or off board. The most conservative case would be railroads that do not allow employees to ride on cars, of which the author knows no example.

### **3.11 Bad Order Options**

If a safety violation exists on a car, it can be bad ordered to one of two locations. If the damage is severe and the car cannot be repaired at its current location, the carman will mark it to be sent to the nearest shop. If the car has less-serious defects, it can be repaired on an Expedite Track. The AAR Interchange Rules (2004) define an expedite track as a repair location not meeting the definition of a repair track (that is, mobile repair vehicles and tracks performing repairs not requiring full repair equipment). The AAR defines a repair shop (facility) / repair track as a location properly equipped, primarily and regularly used for repair of freight cars which must be done in compliance with FRA Railroad Freight Car Safety Standards, Safety Appliance and Power Brake Laws, and AAR Interchange Rules.

An expedite track can be a physical track designation, but can also be a mobile repair vehicle. A repair made on an expedite track does not require the air brakes to be tested on a car regardless of when the car's air brakes were last tested. However, air brakes are required to be tested on a car the first time they are sent to a repair track or facility in a given 12-month period. Thus sending a car to an expedite track versus a repair track saves time and increases car utilization. The location where a defective car is to be sent is noted on the bad order card for that car (Figure 3.2).

PLACED: _____	<b>BAD ORDER</b>			SPOT TO:
TIME: _____				BO _____
DATE: _____				MB _____
CAR INITIAL _____	NBR _____	TYPE _____	PLACE _____	DATE _____
<b>APPLIANCE</b> AL - LADDER AS - SILL STEP AH - HAND HOLD AR - HAND RAIL/CABLE AB - RUNNING BOARD AC - CROSSOVER & STEP  <b>BRAKES</b> BF - CUT OUT BC - CYLINDER BR - RESERVOIR BV - VALVES BP - PIPES, FITTINGS, BRKTS ANGLE COCK, TRAINLINE BB - B.BEAM/HANGER/SUPPORT BL - BRAKE ROD & LEVER BT - PISTON TRAVEL/NOT SET BH - HAND BRAKE BW - HAND BRAKE WHEEL BA - SLACK ADJUSTER	<b>COUPLER</b> CB - BODY CC - COMPONENTS (HEAD) CD - CENTER DEVICE CP - VERTICAL PIN CL - OPERATING LEVER  <b>DRAFT GEAR</b> DY - YOKE DG - GEAR DD - CUSHION DEVICE DR - RETURN SPRING DC - CARRIER IRON DS - STRIKER	<b>END ROOF &amp; BODY</b> EE - END ES - SIDE EH - HOPPER SLOPE SHEET ED - DOOR & GATE EA - TOP CHORD ANGLE ER - ROOF EC - HATCH DOME COVER EP - STAKE POCKET EM - METAL STAKE & POST  <b>FRAME</b> FB - BOLSTER BODY FP - CENTER PLATE FO - OFF CENTER FF - FLOOR BEARER FC - CENTER SILL FS - SIDE SILL FE - END SILL	<b>TRUCK</b> KH - HOT BOX KR - ROLLER BEARING KA - RB ADAPTER KO - WHEEL OUT OF ROUND KW - WHEEL SET KB - BOLSTER KF - SIDE FRAME KS - SPRING & SNUBBER KD - SIDE BRNG DEFECT KC - SIDE BRNG CLEARANCE  <b>OTHER</b> LB - BULKHEAD DOOR RR - REFRIGERATION TA - LOAD ADJUSTMENT/SECUREMENT	
DEFECTS _____				
REPAIRED _____			INSPECTOR _____	
	LOAD _____	EMPTY _____	AIR _____	ROAD _____

**Figure 3.2 Bad order card for a sample Class I railroad**

This is designated by the two options in the upper right corner of the card, BO and MB. BO requires that a car be sent to the repair shop whereas MB denotes a repair that can occur at an expedite track. Railroads generally have a set of in house bad order codes. These bad order NBR codes are classified in the following categories; appliances, brakes, coupler, draft gear, end roof and body, frame, truck, and other. Appliance bad orders are subdivided into ladder, sill step, handhold, hand rail/cable, running board, crossover and step. In addition, the hand brake and operating levers fall under the categories of brakes and coupler, respectively and not under appliances.

If a car is bad ordered it is considered out of service. Additionally, if it is tagged “home shop for repairs”, is in a repair shop or track, is in a storage track and is empty, or has been delivered in interchange but not accepted by the receiving carrier, a railcar is also classed as out of service. This is important in the event that an injury or accident involving the car occurs, as well as making the car immune to FRA safety appliance citations.

Safety appliance bad orders can be avoided if the car is repairable in the yard using a graduated pry-bar or other applicable tool to perform a “yard repair”. These repairs are not generally tracked and increase car utilization because the car is not removed from service while the repair is made.

There are no requirements for tagging safety appliance defects (FRA 2004a) and the author is unsure why this is the case. It would seem that the FRA would need to distinguish between cars with known defects being hauled to the nearest repair location and those with defects that have not yet been identified. These two cases result in substantially different responses from the FRA. It also seems that cars should be tagged to warn unsuspecting employees of a car that has safety appliance defects.

### **3.12 Current Railroad Car Inspection Process**

The current inspection process relies primarily on human vision to accomplish the task of identifying railcars with defective safety appliances. Car inspectors are tasked with identifying not only safety appliance defects, but a number of other mechanical defects as well. Carmen inspect trains by walking or riding a vehicle alongside the train. There are a variety of approaches to inspecting trains for safety appliance defects. Three different examples for flat-switched yards are depicted in Figure 3.3.

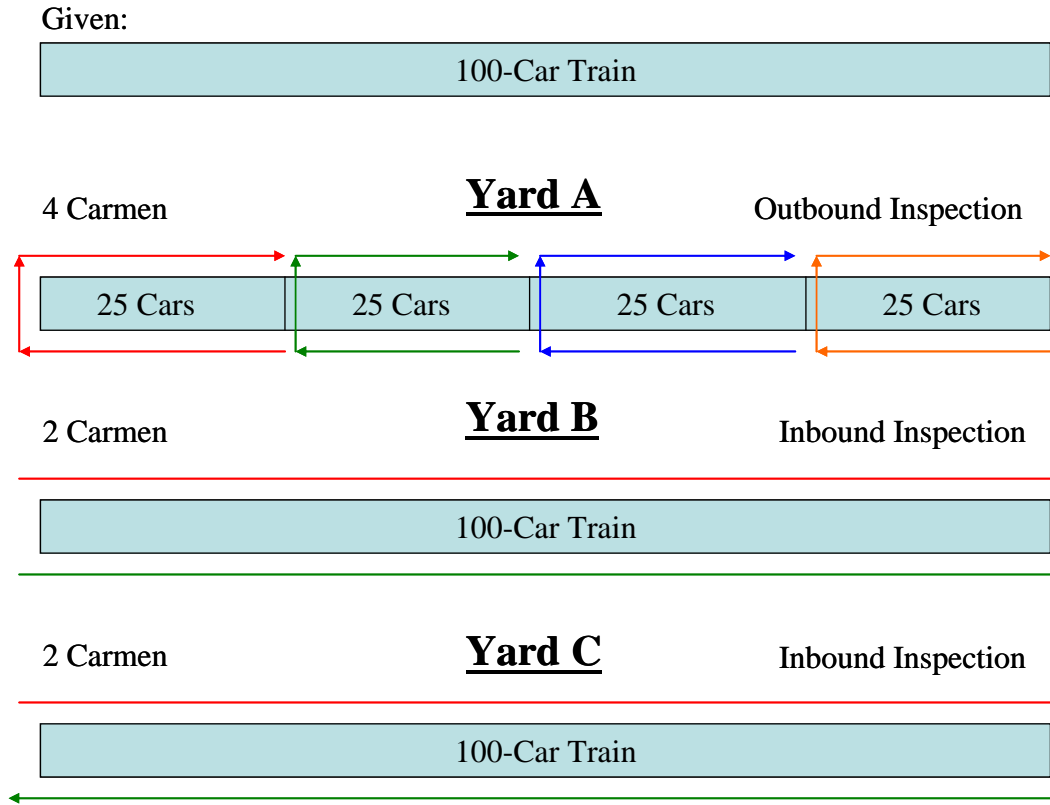

**Figure 3.3 Three different approaches to inspection at three Class I rail yards**

Yard A is the highest volume yard of the three, inspecting about 2,800 cars per day and uses four carmen to inspect trains. Each train is broken up into four blocks, and the carman laces his or her cars before crossing over and inspecting the opposite side of their portion of the train.

Yard B is a smaller yard, inspecting about 800 cars per day on inbound trains by using two carmen per train. The two carmen start at the same end of the train and walk in parallel on opposite sides of the train, allowing for communication between the carmen as they walk along the train.

Yard C also uses two carmen to inspect trains, but they start at opposite ends of the train. This yard is performing 1,000-mile brake inspections so the trains remain intact



and depart following inspection and other activities. It operates similarly to a stub-end yard, with a large number of trains entering and leaving from the same end. As many as 3,600 cars may pass through each day, considerably more than either Yard A or B. As a train enters the yard, one of the two carmen is awaiting its arrival at the entry end of the yard and performs a roll-by inspection of one side of the train while the other awaits at the end of the arrival track. Once the train is stopped and the track is blue flagged, the carman begin their inspections traveling in opposite directions from either end. After the inspections are complete the two carmen communicate with one another confirming that they have finished their inspection. The carmen that was previously at the stub end of the yard is now at the front of the departing train and gives a roll-by inspection to the second side of the train as the train departs.

All three methods use the same number of person-hours, but result in different turnaround times. The amount of traffic dictates how many inspectors are on hand at a given yard and may also dictate whether or not the cars are inspected on the inbound or the outbound. Yard A inspects cars on the outbound, whereas Yards B and C inspect cars on the inbound. The differences in inspection time between Yards B and C come in differing times needed to stage carmen to perform the roll-by inspections and also the type of inspections being completed. Class IA brake inspections are being performed at Yard C whereas pre-departure inspections are being performed at Yard B.

### **3.13 Train Inspections and Yard Efficiency**

Inbound inspections are a critical part of the car handling process. Generally, as a train enters a yard it is spotted on a receiving track where the locomotives and the EOT device are detached. Next, the cut of cars (which is no longer a train due to the EOT

device being removed) is inspected before an engine takes it to the hump or switching lead. In other words, the barrier between having a string of cars ready to hump and a string of cars that cannot be removed from the receiving tracks is the inbound car inspection. Once again, on the outbound, before a train can depart from a yard and after the EOT device is attached, a Class I brake test must be performed per FRA regulations. Both of the inspection tasks tie up capacity at receiving and departure tracks respectively

One benefit to increasing the efficiency of inspections would be the increased virtual capacity to the receiving and departure tracks. If train inspections are expedited through automated means, trains may be able to clear arrival and departure tracks in less time. This method of increasing capacity could be beneficial in yards that are at or near capacity and in need of additional track but are currently constrained from doing so for various reasons. The resulting increases in throughput would result in lower train delay costs and an overall increase in yard fluidity as well as provide for greater utilization of tracks thus lessening the need for additional track design (Dirnberger 2006).

## **CHAPTER 4: RAILROAD SAFETY APPLIANCE STANDARDS, CFR PART 231**

The Code of Federal Regulations Title 49 Part 231 is known as the Railroad Safety Appliance Standards (FRA 2004b). The Railroad Safety Appliance Standards apply to all standard gauge railroads with a few exceptions. These exceptions are mostly railcars that operate completely within a facility and are not in interchange service. In addition, rapid transit systems that are not connected with the general railroad system are not covered in under 49 CFR Part 231. Four-wheeled coal cars and logging cars of eight wheels are not covered under the Railroad Safety Appliance Standards if the center of coupling is not more than twenty inches above the top of rail. Finally, except for uncoupling device provisions, Part 231 does not apply to Tier II passenger equipment, which operates at speeds exceeding 125 miles per hour.

Each car type is described within its respective section of the Railroad Safety Appliance Standards. For the purpose of this thesis, the specifications for box and other house cars built or placed in service before October 1, 1966, section §231.1 in Part 231, are discussed. All cars are similar in terms of safety appliance requirements, and the regulations for many other cars types reference the section on box and other house cars without roof hatches, making this type a good candidate for explanatory purposes. The following example does not cover each parameter listed in Part 231, but the critical ones for open-top hoppers and gondolas with high sides are noted and explained. In addition to the respective sections for cars, there is a section pertaining to drawbar heights.

Drawbar heights for all cars are covered in §231.31 and the center of drawbar should be between 31.5 and 34.5 inches above the top of rail.

#### **4.1 Handbrakes**

One vertical wheel handbrake, which can be of any efficient design, is required for each car with the total braking force no less than that pressure that is applied to the brake shoes when the brake cylinder is at fifty-pounds per square inch. The brake wheel may be deep or shallow and constructed of malleable iron, wrought iron, steel, or equivalent material with a nominal diameter of twenty-two inches. The depth of the brake wheel hub shall be two and five-eighths inches with a square taper shaft fit, tapering two inches in twelve inches with a small end of the taper fit seven-eighths inches. When wound in a counterclockwise direction, the brake wheel can have no means of preventing applications. The brake shaft shall be not less than seven-eighths of an inch square with a square fit taper. All handbrake chains should be no less than nine-sixteenth inch BBB chain and handbrake rods shall be no less than three-fourths inch diameter. The handbrake shall be located between seventeen and twenty-two inches from the center of car so that it can be operated from the horizontal end platform while the car is in motion. Handbrakes should not be between twenty-six and forty inches from the top of end-platform tread. Brake wheels should be held in place by a nut

on threaded shaft (of three-fourths inch) and the nut should be secured by riveting over or by the use of a locknut of suitable cotter. The outside edge of the brake wheel should not be less than four inches from a vertical plane which passes through the inside face of knuckle when closed with the coupler horn against the buffer block. The handbrake housing should be securely fastened to the car.

#### **4.2 End Platforms**

Two end platforms shall be provided with a width no less than eight inches and length no less than sixty inches. One platform should be centered on each end of a car between inner ends of handholds no more than eight inches above the top of center sill. Three metal braces should support the end platforms with a minimum cross sectional area of three-eighths by one-half inches secured using one-half inch bolts or rivets. Depending on whether the longitudinal travel in the draft gear is greater than or less than twelve inches, the platform should be located no less than six or no less than twelve inches from the inside face of knuckle when closed with the coupler horn against the buffer block. The platform can be made of wood or other material with the same or greater degree of safety, and should be constructed to allow for the elimination of snow and ice.

### **4.3 Sill Steps**

Four sill steps with a minimum cross sectional area of one-half by one and one-half inches made of wrought iron, steel, or other material of equivalent strength should be located on cars, with a ten (preferably twelve) inch tread and eight inch clear depth. One shall be located near each end of the car with no more than eighteen inches between the center of sill step and end of car. The outside face of the step should be no more than four inches inside of the face of car, preferably flush with the car. The tread should be no more than twenty-four (preferably twenty-two) inches from the top of rail. Any sill step exceeding twenty-one inches in depth shall have an additional tread, and all sill steps shall be fastened with one-half inch bolts with nuts on the outside and one-half inch rivets.

### **4.4 End Ladder clearance**

No part of the car other than the buffer block, brake shaft, brake wheel, end platform, horizontal end handholds, or uncoupling lever that is within thirty inches of side of car shall extend to within twelve inches of a vertical plane parallel with the inside face of knuckle when closed with the coupler horn against the buffer block at full buff. Other than the ones noted, no part of the car shall extend beyond the outer face of the buffer block.

#### **4.5 Side Handholds**

Sixteen side handholds with a minimum diameter of five-eighths inches made of wrought iron, steel, or other material of equivalent strength should be located on cars, with a twelve (preferably twenty-four) inch minimum clear length and two (preferably two and one-half) inch clearance. Four should be located on each end of the car located no more than nineteen inches apart with the bottom handhold no more than twenty-one inches above the top tread of the sill step. The top handhold should coincide with the top end handhold, within a 2" variance. Spacing of side handholds should be within two inches of bottom handholds with a clearance of the outer end of the handholds being no more than eight inches from the end of the car. The side handholds should be securely fastened with no less than one-half inch bolts with nuts on outside and riveted with no less than one-half inch rivets. Bottom handholds should have a foot guard or some type of upward protection no less than two inches in height near the inside end.

#### **4.6 End Handholds**

Sixteen end handholds with a minimum diameter of five-eighths inches made of wrought iron, steel, or other material of equivalent strength should be located on cars, with a sixteen (preferably twenty-four) inch minimum clear length and two

(preferably two and one-half) inch clearance. For horizontal handholds, four should be located near each side and on each end spaced no more than nineteen inches apart. The bottom handhold should be no more than twenty-one inches from the top tread of sill step with top handhold coinciding in height (within two inches) with the end platform handholds. The end handholds should be securely fastened with no less than one-half inch bolts with nuts on outside and riveted with no less than one-half inch rivets. End handholds should have a foot guard or some type of upward protection no less than two inches in height near the inside end.

#### **4.7 Horizontal End-Platform Handholds**

Two horizontal end-platform handholds with a minimum diameter of five-eighths inches made of wrought iron, steel, or other material of equivalent strength should be located on cars, with a sixty-inch minimum clear length and a two (preferably two and one-half) inch clearance. One should be located on each car between forty-eight and sixty inches above end platforms no more than six inches from the inner legs of top end handholds. The horizontal-end platform handholds should be securely fastened with no less than one-half inch bolts with nuts on outside and riveted with no less than one-half inch rivets.



## **4.8 Uncoupling Levers**

Handles not conforming to Plate B should be no more than six inches from the side of car with one on each end of the car. Plate B handles should be no more than twelve (preferably nine) inches from the side of cars and have a center lift arm of no more than seven inches. In addition, Plate B handles should have a center of lift arm of no more than three and one-half inches beyond the center of the coupler. Handles should extend no less than four inches below the bottom of the sill step with two inches of clearance around handle. The minimum drop of handles is twelve inches, or fifteen inches overall. All handles of uncoupling levers of the “rocking” or “pushdown” type shall be no less than eighteen inches from the top of rail when the lockblock has released the knuckle. A stop shall be provided to ensure that the inside arm does not fly up in the event of a breakage. One handle shall be placed on the left side of each end of the car.

## **CHAPTER 5: SAFETY APPLIANCE INSPECTION COST MODEL**

### **5.1 Introduction to the Industrial Inspection Process**

Inspection, in manufacturing applications, is defined as the process of determining the conformance of a product to a given set of requirements (Cielo 1998). In a manufacturing environment, a product may be inspected at various points during the manufacturing process to ensure quality conformance, but once the product is constructed and exits the manufacturing process, the inspections cease. Unlike the industrial inspection process, railcar safety appliances are repeatedly inspected over the lifetime of the railcar. Despite this difference, there are some correlations between the manufacturing inspection process and the method railroads use for mechanical car inspections, including safety appliance inspections.

Safety appliances receive an inspection that is analogous to the industrial quality conformance inspection, but this occurs only during construction and possibly immediately after the construction process. Additionally, when a railcar design is generated by a car manufacturer the FRA must approve the safety appliance design through a “sample-car inspection” that ensures the appliances are compliant before the car type is placed in service (FRA 2004a).

The number of defect types encountered in typical industrial inspection processes is likely to be less than the number encountered in the railroad car inspection process. In the industrial inspection process, there are typically a limited number of defect types to be expected as the product passes down the assembly line due to the relatively controlled environment. This is not the case for railcar safety appliances as there are a multitude of

damage types that occur during its operation. Each safety appliance has many parameters that must be in compliance with the possibility that each is in violation in a variety of ways. For instance, the 2” clearance of a ladder rung could be in violation at any point along the rung, creating a myriad of possible instances of deformation resulting in an FRA defect. While these different forms of deformation may not be difficult for human vision to detect, their detection is nontrivial when it comes to writing computer algorithms capable of detecting all the possible forms of deformation that could cause a car to be non-compliant.

Inspections can be carried out by human or automated means, or as a combination of the two. The current process calls for railcars to be repeatedly inspected to ensure their mechanical components are functional. The repetition of railroad car inspections stems from the large number of components that must be inspected on a railcar, and the short amount of time available to inspect them during typical inspections.

The manufacturing industry is well suited for automated inspection due to the uniformity in parts that travel down a given assembly line. This is because, in a manufacturing plant, there is a production line producing a constant stream of identical goods. The railroad inspection process is similar as there is still an assembly line (yard lead or any track) that the product (railcars) traverses when leaving or entering a yard. However, in many North American rail yards, the types of railcars passing through and requiring inspection vary enormously. There are 1.3 million railcars of hundreds of types and varieties in operation in North America (AAR 2003b). Inspection systems, whether human or mechanized, must be able to accommodate any and all of them. Conversely, there are some locations in North America that have only a very limited number of car

types. For example, rail cars operating in the Powder River Basin of Wyoming and Montana are highly uniform. Inspectors working in these locations may see hundreds of railcars of a specific type in a given shift. At other yards, the distribution of car types is more uniform and inspectors are faced with multiple car types within a shift and even within a given train. It is unknown what affect, if any, these differences have on the effectiveness and efficiency of inspections.

## **5.2 Types of Industrial Inspection Processes**

In the manufacturing industry there are several types of inspection processes; batch, patrol, and continuous inspections (Cielo 1998). Batch inspections involve the inspection of a small percentage of goods after the production process. Determining batch size involves statistical analysis based on the percentage of defective parts that are considered acceptable for the particular process. Patrol inspections involve a control officer making rounds during the inspection process searching for defects that are readily visible on some, but not necessarily all, of the parts produced.

Railcar inspections do not fall into either of these inspection types but instead are the third and strictest type, continuous inspection. In a continuous inspection process, one hundred percent of objects (railcars) are inspected prior to being released (departing). The need for “continuous” inspection of railcars stems from the criticality of complying with safety standards and the large number of components that must be inspected.

## **5.3 Relationship Between Inspection Rate and Defect Detection**

Carmen often inspect hundreds of cars per day, sometimes as many as 1,100 – 1,200 cars per shift. Such a large number of inspection units may lead to missed defects

for several reasons related to human capabilities. One hundred percent conformance refers to one hundred percent of the actual defects being identified and is not realistically produced even with 100% inspections. In manufacturing, 98% conformance is considered good and levels as low as 80% are often found (Cielo 1998).

The acceptable level varies depending on the relative cost of detecting defects relative to the cost of allowing the defects to persist or changing the manufacturing process to prevent them. In this sense it is an optimization problem and each such process will have a different optimum depending on the relative functional relationships of these parameters. The optimization of the railcar inspection process will be discussed in Section 5.4, Qualitative Inspection Cost Model. One obstacle to humans' ability to achieve 100% inspection is the inherent monotony of many inspection tasks. Certain inspector characteristics increase the accuracy of inspections such as conscientiousness, patience, ability to thwart fatigue, aptitude, and a rhythm for inspecting (Kennedy and Andrews 1977, Cielo 1998).

The functional relationship between the number of defects escaping inspection and inspection rate is not as simple as intuition might suggest. Audited studies of inspection effectiveness indicate a more complex relationship (Kennedy and Andrews 1977). A typical inspector completing 100% inspections at differing inspection speeds shows the effect of inspection rate on percent conformance (Figure 5.1).

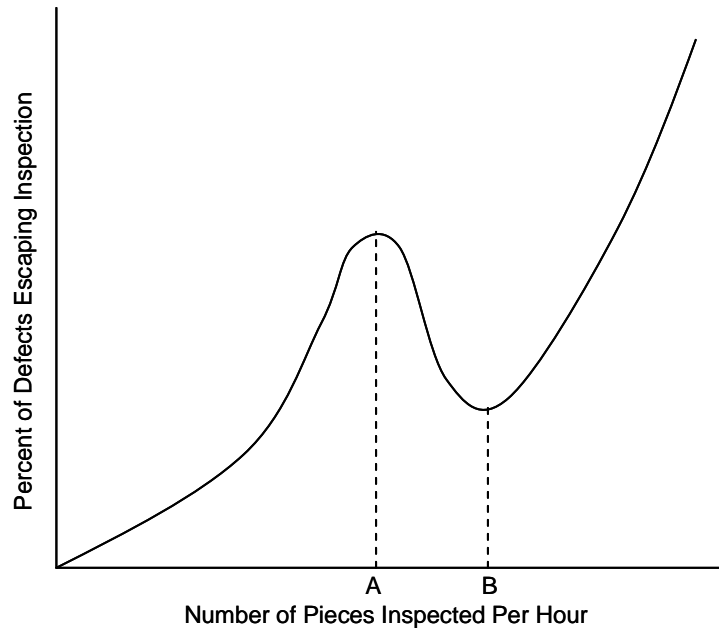

**Figure 5.1 Functional relationship between percent of defects escaping detection and inspection rate of a human inspecting using 100% inspection (Kennedy and Andrews 1977)**

When inspection rate is low, the number of missed defects is also low (Figure 5.1). As inspection rate increases, so does the percentage of defects that are missed until a local maximum is reached at point A. As the inspection rate continues to increase after point A, the percentage of defects escaping detection actually decreases due to reduction in monotony until it reaches a minimum at point B. Beyond point B, the percentage of defects missed increases once again as fatigue and the limits of human cognitive ability begin to have a greater effect and the percent conformance decreases.

Applying this model to railcar inspection should be done with some caution however. The functional relationship described in Figure 5.1 applies to inspections of like pieces inspected under consistent conditions. This is not necessarily the case with railroad safety appliance inspections. It is also important to consider the varying levels of difficulty of inspecting different safety appliances using current methods. For instance, a

handhold that violates the 2” clearance rule may be more easily detected than a brake wheel that violates the 4” clearance rule. Beyond this, different parameters for the same safety appliance have varying levels of difficulty in identification depending on the location of the appliance. If a rung on a ladder is damaged at eye level, it may be easily detected, but if the top ladder rung on a car is damaged, it may be difficult to detect.

Based on field visits with carmen at several Class I rail yards, it is evident that individual carman have different aspects of the railcar that they are more attuned to. At one yard a carman identified his fellow carmen by what aspects of the car they were known for detecting defects on. In theory, the variation in types of defects found by carmen adds to the effectiveness of the current inspection process. This is assuming that each carman is capable of detecting many types of defects, but is specialized in detecting one type of defect. This, coupled with the fact that cars are randomly assigned to carmen means one carman does not repeatedly see any one car. Over time, cars pass by a variety of inspectors, each with the ability to scrutinize one aspect of the car better than the last inspector. However, such a system is haphazard at best, and does not address those defects that are uniformly difficult to detect.

#### **5.4 Qualitative Inspection Cost Model**

There are costs associated with any inspection process, including railcars. These can be broken down into three categories; failure costs, improvement costs, and total inspection costs (Cielo 1998). Analyzing these three inspection costs is known as quality cost analysis and allows one to determine the optimal amount that should be spent on quality conformance (Feigenbaum 1983). In this section I adapt a general manufacturing inspection cost model developed by Cielo (1998) to the railroad car inspection process

and then explore how new applications of enhanced railcar inspection technology might affect that model.

#### *5.4.1 Failure Costs*

Costs of failures in railcar inspections come in several forms; FRA fines, delay cost of setting out damaged or defective cars if they are discovered once they are in an outbound train, the risk of a train accident caused by a defective car, or of injury or death to employees due to missed defects. FRA fines are not levied on all non-compliant safety appliances but when they are, they range from \$500 to \$7,500 per violation (FRA 2004b). Each day that a safety appliance violation occurs constitutes a separate violation (FRA 2004b). The costs of injury or death are the costs of litigation due to an incident involving defective safety appliances. The cost due to train delay results from setting out a car prior to departure after a safety appliance violation was found on an outbound inspection that should have been found on the inbound inspection. The resulting costs apply to the cumulative delay for all of the cars and locomotives on the train, as well as the costs of the crew.

Additionally, other trains may be delayed as a result of the defective car being set out by the original train. Train delays can significantly impact the fluidity of the overall network. Furthermore, if the car had been noticed on the inbound it could have been under repair during the time it spent in the yard thereby improving asset utilization.

#### *5.4.2 Improvement Costs*

Improvement costs will generally increase with conformance percentage. There are three typical approaches to increasing conformance percentages for safety appliances:



1) reduce the rate (speed) of inspection, 2) increase the aptitude of inspectors through better training, or 3) incorporating some type of technology to enhance inspectors' ability to perform their task. Slowing the rate of inspection will reduce productivity and will require either more carmen, or longer hours for the same number of carmen. In either case, slowing the rate of inspection will lead to higher labor cost. Providing carmen with additional or improved training and guidance may also prove useful in raising the conformance percentage. This has been the principal approach used by the railroad industry and it is beneficial; however, due to limitations in human physical, sensory, and cognitive capabilities there will ultimately be diminishing returns to this approach.

Costs associated with improving inspections become incrementally larger as 100% conformance is approached (Figure 5.2). One hundred percent conformance is only hypothetical, as the improvement cost curve (Figure 5.2) never reaches the point of complete conformance (Cielo 1998). As a carman inspects a train, the most obvious defects are those that would be flagged first, with the more difficult ones being detected at a decreasing rate relative to the effort expended. Thus, as more time is spent inspecting a given train, more defects will be located. Each additional incremental amount of time and effort detecting defects should return more defects, but will do so at a decreasing rate. For example, as previously explained, FRA inspectors spend more inspection time per car than railroad carmen, thus their rate of conformance should be higher.

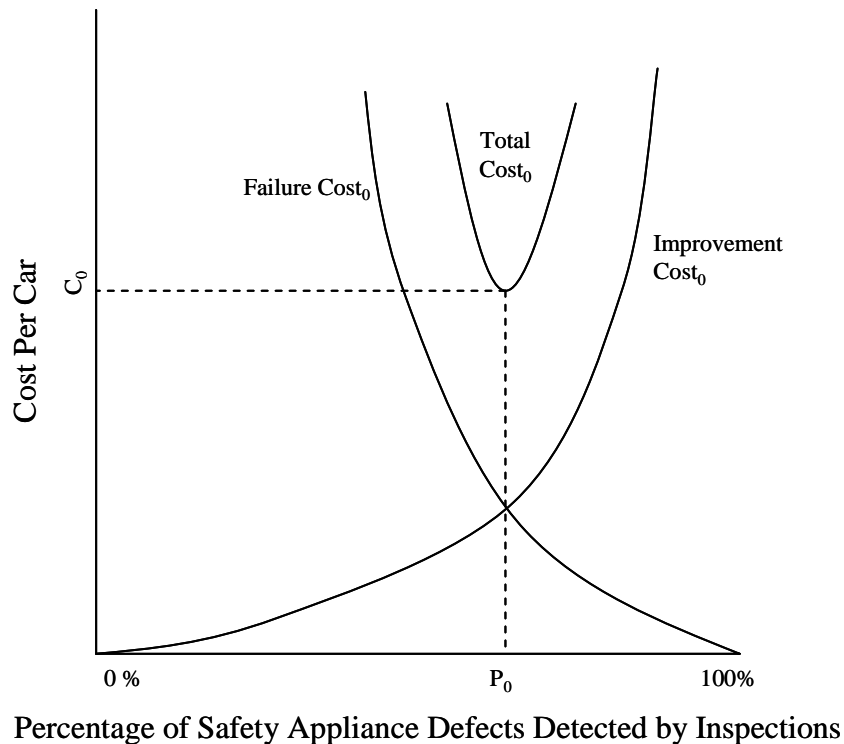

**Figure 5.2 Qualitative model of optimum inspection costs as inspections are currently performed ( $P_0$  and  $C_0$ ) (Kennedy and Andrews 1977)**

There is also an opportunity cost for railcars awaiting inspection. The current visual inspection method results in dwell times of nearly an hour as a train is inspected. To the extent that railcar productivity is reduced by inspections the result is the need for an incrementally larger railcar fleet. Additionally, in a busy yard, other trains may be delayed while they await inspectors to complete their task, further increasing costs and reducing service quality.

#### 5.4.3 Total Costs

Figure 5.2 shows a plot of all three curves. The x-axis represents the number of safety appliance defects that are correctly flagged by inspectors, or the conformance percentage.  $P_0$  is the point of optimum conformance. The y-axis represents the cost of

inspection per car. The optimum cost of inspection occurs at  $C_0$ , where the total cost curve is at a minimum. The total cost curve is the summation of the improvement and failure cost curves. The point of minimum cost ( $C_0$ ) is also the point where the inspection effort is minimized. This cost can be directly equated to an amount of time that should be spent to inspect a railcar if the objective is to maximize the economic efficiency of railcar health and inspection costs.

### **5.5 Qualitative Inspection Cost Model after the Addition of New Technologies to the Inspection Process**

Improvements in the railcar inspection process would shift the total cost curve (Figure 5.2). These improvements could be as simple as changes in inspection methodology or additional tools for the carmen or involve use of sophisticated technology such as use of machine vision for railcar inspection. Such enhancements will not generally affect the failure cost curve for car inspections; however, the improvement cost curve would be affected (Figure 5.3) because of the lower unit inspection cost for inspections. The benefits of using additional technologies such as machine vision to monitor railcar safety appliances are twofold; 1) it will reduce the cost of inspection and 2) fewer defects will pass through the inspection, resulting in a higher conformance percentage. A reduction in costs ( $C_0 \rightarrow C_1$ ) would occur if the operating costs of a machine vision system were less than the current system. An increase in conformance percentage ( $P_0 \rightarrow P_1$ ) would occur as a result of machine vision systems being objective and providing more reliable results. The result is a system that is both more effective and efficient, and thereby safer and more economical.

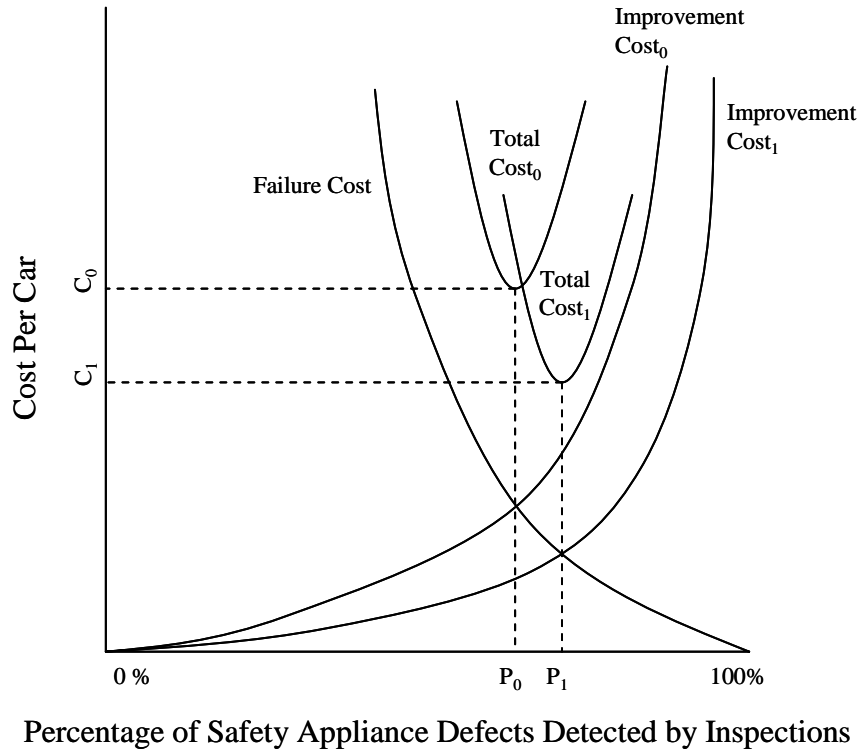

**Figure 5.3 Qualitative model of optimum inspection costs after the addition of additional technology to safety appliance inspections ( $P_1$  and  $C_1$ ) (adapted from Kennedy and Andrews 1977)**

## **CHAPTER 6: METHODS OF IMPROVING THE EFFICIENCY AND EFFECTIVENESS OF RAILROAD SAFETY APPLIANCE INSPECTIONS**

One means by which the efficiency and effectiveness of car inspections can be increased is through the use of technology. There are multiple technologies that are currently being employed to aid in the inspection of mechanical components of railcars. An example of wayside rail vehicle health monitoring system that includes a memory capability is the Wheel Impact Load Detector (WILD). WILDs detect vertical loads at wayside installations and report the information to a central system that monitors rail vehicles' performance (Morgan and Anderson 2003, Luzcak 2005). Another wayside vehicle monitoring system is the Truck Performance Detector (TPD) that detects poorly performing trucks by monitoring lateral loads. The Transportation Technology Center Inc. (TTCI) is also deploying a new visual inspection system known as FactIS to inspect railcar truck components including wheels, brake shoes, and other mechanical components.

### **6.1 Machine Vision Overview**

Machine vision can be used for a number of railcar inspection tasks (Hart et al 2004, Lai et al 2005), including many aspects of safety appliance inspections. Machine vision consists of capturing digital images and using algorithms to detect certain attributes in these images. In the context of this work, these images are of railcar safety appliances and the attributes are various forms of defects or deformation.

The terms computer vision and machine vision are generally associated with one another. Generally, computer vision refers to the field in general and machine vision is used when referring to industrial applications of the technology (Shapiro 2001).

The most common input devices for machine vision systems are charge-coupled device (CCD) sensors (Shapiro 2001). CCD cameras work by converting light energy from each cell into an electrical charge. The CCD camera plugs into a computer with a frame grabber. The frame grabber is capable of storing the images and also controls the camera. With new technologies such as FireWire, which provide a digital signal, traditional analog frame grabbers are not necessary (Shapiro 2001, Hart 2006). Many newly manufactured personal computers (PCs) are equipped with a FireWire port (Hart 2006).

Videos intended for human viewing are generally captured at a rate of 30 frames per second (Shapiro 2001). Specifically, these frames are captured at a rate of 60 half-frames per second, allowing the video to be perceived smoothly by humans. A frame rate of 60 half-frames per second is unnecessary for machine vision purposes, and a rate of 30 frames-per-second works sufficiently for many applications unless the speed of the inspection process dictates a higher rate.

## **6.2 Comparison of Human Vision and Machine Vision**

Understanding the strengths and weaknesses of human and machine vision is helpful in understanding the possibilities of machine vision. Humans are capable of analyzing complex and dynamic situations. However, humans are not as good at performing repetitive inspections without suffering from boredom and fatigue. Additionally, for many tasks, humans are not as reliable at judging objects with the level

of objectivity and consistency that is inherent in machine vision (Batchelor 2005). Machine vision systems have a higher first cost associated with the initial implementation of the system than does a human counterpart, but may have a lower operating cost, depending on the number of units to be inspected. Machine vision does not easily adapt to unforeseen events, but for certain types of consistent, repetitive tasks – precisely the ones humans become ineffective at – machine vision may offer more reliable, lower cost inspection. A comparison of machine and human vision attributes is summarized in Table 6.1.

<b>Situation</b>	<b>Machine Vision</b>	<b>Human Vision</b>
Performance of repetitive tasks	Good	Poor
Consistency	Good	Poor
Ability to cope with unforeseen events	Poor	Good
Capital costs	Moderate	Low
Inspection cost, per unit	Low	High

**Table 6.1 Comparison of relative advantages and disadvantages of human and machine vision (Batchelor 2005)**

### 6.3 Automation and Memory

Inspections can occur either with or without some type of memory. Currently, the majority of car inspections are completed manually and the results are not recorded. Memory could be added to the current system through the use of a Personal Data Assistant (PDA). Carmen would enter defect information into their PDAs, which would be downloaded and used later as a means of tracking defects or planning maintenance. As of 2006, a system such as this is being tested on at least one Class I railroad.

Utilizing technologies without memory is useful in the short term, aiding mechanical personnel in the detection of defects, but it does not provide a means of tracking a railcar’s health through time. This would have the advantage of making the

system less memory intensive from a data storage perspective. However, the addition of memory to the inspection process could enhance the effectiveness and value of the machine vision system by improving maintenance scheduling and efficiency. While all FRA safety appliance defects must be repaired before a train can depart a yard, there are other forms of deformation that could be repaired as time allows. For instance, if a ladder is deformed, but not a FRA defect, it would likely be repaired in its next visit to a repair facility. Memory in the inspection of railcars could lead to better scheduling of upcoming maintenance on a railcar, and ensure the needed parts are in stock or on the way before the car arrives at the facility. Examples of system memory could range from storing digital images for image correlation purposes, or matching safety appliance data with car numbers and storing this information in a database.



## **CHAPTER 7: MACHINE VISION SYSTEM FOR THE DETECTION OF SAFETY APPLIANCE DECECTS**

In this chapter I describe the decisions involved with selecting the location and viewing parameters of a machine vision inspection system for railcar safety appliances. This includes both macro and micro level considerations ranging from the location on the railroad network where inspection systems should be installed, to the specific camera angle needed for collection of safety appliance images that are satisfactory for analysis of the desired parameters. I also discuss the primary components of the machine vision system capable of detecting defective railcar safety appliances. These components are the image acquisition system, algorithms, and field setup for a machine vision system.

The location of a machine vision installation for monitoring safety appliances can be broken down into three aspects. The first of these is the *location* of the inspection site on the railroad network. Secondly, the *view* must be identified. The camera view is the portion of the railcar that is captured within the image frame of view. Once the view is set, the camera *angles* must be determined to ensure the needed safety appliance parameters are captured.

### **7.1 Machine Vision System Locational Requirements**

There are many factors involved in the decision of where a machine vision system should be located with the goal of providing the greatest benefit to the railroad and integrating the system with railroad operations. The use of the data that will be captured by the installation should dictate the location of the installation. Data can be used for FRA mandated inspections, preventative maintenance, planned maintenance, or some

combination of the three purposes. There are two general locations for a machine vision system capable of detecting defective safety appliances; 1) at a location where trains are funneling into a terminal and 2) on the road between terminals. Regardless of the use of data, the detection system will need to be a sufficient distance outside of a terminal to allow for the processing and transfer of information on defective safety appliances, interpretation by the appropriate mechanical personnel at the yard, and decisions to be made regarding how each car is to be handled when it arrives.

Data for FRA-required inspections should be captured early enough to allow mechanical personnel to have information on defective cars in hand when an inbound train arrives on a receiving track. There are additional issues that must be considered if the data are to be used to perform FRA-required inspections. One question concerns between-terminal locations and how mechanical defects are handled after they have been identified. If a car has a safety appliance defect, current practice is to set it out at the nearest location that a suitable repair can be made as required in the safety appliance statute. If a mobile repair vehicle is assigned to the area, the nearest location where a repair could be made would likely be closer than the next terminal. This would require the train to be stopped and the car set out before reaching a terminal.

The issue of whether or not to stop a train for safety appliance defects detected by a wayside machine vision installation should be resolved between the AAR, railroads, and the FRA as machine vision inspection of railcars becomes more prevalent. The development of new technology-driven inspection capabilities will raise issues that need to be addressed, lest they stymie development and implementation of new more effective and efficient technologies that can improve safety and railroad performance.

Data for preventative or planned maintenance could be gathered at either the between-terminal or terminal entrance locations, depending on how much time the mechanical department at the repair location needs to react to the information. Planned and preventative maintenance will generally not apply to safety appliances because defects tend to occur as a result of acute events rather than long term wear. By contrast, use of wayside inspection systems is likely to be useful for detecting defects and wear on mechanical components, such as brake shoes thereby improving inspection efficiency. For example, mechanical personnel at an upcoming terminal will know the number and type of brake shoes required for repair of cars in an inbound train before it arrives.

Once mechanical defects are detected on the railcar, this information must be transmitted in a useful form to railroad personnel. All railcars in North America are equipped with Automatic Equipment Identification (AEI) tags, which identify cars and provide certain other basic information. Generally, wayside detection systems are located in close proximity to AEI installations. In addition to the AEI encoded information, the car number can be used to query the Uniform Machine Language Equipment Register (UMLER) for additional car specific information if needed. This will provide car type information that is needed to determine which part of CFR Part 231 the car is governed by. Safety appliance health may be tracked in some type of a database, but the specifics of this database have not yet been developed. Some methods of determining the health of safety appliances may circumvent the need to have a database of safety appliance information, or reduce the data to a few binary fields representing classes of defects.

## 7.2 Camera View

The goal in camera view selection is to capture the maximum number of safety appliances with a minimum number of cameras. In addition, each camera view must be evaluated in terms of how many safety appliance parameters can be identified from the view. I considered the advantages and disadvantages of each camera view for the safety appliances addressed in this phase of the project. In considering this section, knowledge of CFR Part 231 is necessary, an overview of which can be found in Chapter 4. The camera views that will be considered are; perpendicular side, perpendicular overhead, angled from above, angled from the side, and angled from the side and upward from below rail height.

### *7.2.1 Perpendicular Side View*

Figure 7.1 shows the side view perpendicular to the tracks. This camera view has been successfully used in another project imaging intermodal train loading configurations (Lai et al 2005). In that project the camera was set a distance of approximately 35.5 feet from the track center. The perpendicular angle provides a good view of brake wheel clearance and vertical displacement of side ladder rungs. On the other hand, it is impossible to detect any aspects of the end ladder from this angle and it is also not possible to determine if there is adequate clearance between ladder rungs and the car body. Finally, it is difficult to detect sill step deformation in plane with the side of the car body (e.g. violating the rule of being more than 4" inside the face of the car). Only one camera is required to analyze a train from the perpendicular side view.



**Figure 7.1 Perpendicular view of the railcar**

### *7.2.2 Perpendicular Overhead View*

A view from above the tracks was also considered. There are several means by which a railcar can be imaged from overhead. The first of these is with the camera looking straight down perpendicular to the tracks (Figure 7.2). This angle provides a suitable view of both the brake wheel clearance and possibly even end ladder clearance given the fact that the train can be imaged at a frame rate that provides the optimal image for this recognition task. However, this view does not provide a vantage point for identifying vertical displacement of side or end ladders rungs and the sill step is not visible. A camera capable of capturing this view would need to be mounted on some type of structure above the track. Like the perpendicular side view, only one camera is required to analyze a train from the perpendicular overhead view.



**Figure 7.2 Perpendicular overhead view of a railcar**

### *7.2.3 Angled Overhead View*

Some of the disadvantages of the perpendicular overhead view could be overcome by the use of an angled overhead view (Figure 7.3). With the camera placed at the correct angle on each side of train (two cameras total), each rung of the ladder is visible. A disadvantage of overhead views is that they create a background problem. Safety appliances would be imaged on a moving train that creates moving shadows on the substrate that provides the background. This complication of the safety appliance recognition task caused me to consider other viewing angles.



**Figure 7.3 Angled overhead view of a railcar**

Another drawback to this location is the need to perform a perspective correction because the car is not being imaged normal to any one surface. This effect is known as foreshortening and there is an algorithmic solution to this problem, known as unforeshortening.

#### *7.2.4 Angled Side View*

An angled view from the side of the tracks was considered (Figure 7.4). At the correct angle in the vertical plane (referring to the camera's location with respect to the top of rail) it is possible to see ladder rung clearance as well as vertical displacement of ladder rungs. This camera location would be near the surface of the ground and is more accessible than one that is located above the tracks. This view would require four cameras to image the four corners of each railcar. Like the angled overhead view this view would also require foreshortening correction.



**Figure 7.4 Angled side view of railcar**

#### *7.2.5 Upward Angled Side View*

None of the cameras views described allows for imaging all of the parameters of the safety appliances considered in the initial phase of this project. The perpendicular view did not allow for ladder rung and handhold clearances to be imaged, which is one of the most critical parameters in CFR Part 231 according to Class I railroad mechanical management. Additionally, both of the locations above the railcar involve placing a camera in locations that are less accessible and also create a background problem. With some manipulation, the angled side view would provide the needed view to identify deformation in ladder rung clearance as well as vertical rung spacing.

Based on this, it was decided that the corner post of the car should be in the leading position when the optimal image is taken. Furthermore, the angle between the camera and the tracks should be  $45^\circ$  (Figure 7.5). Finally, the camera should be lower than the top of the rail and aimed upward at an angle to be discussed in the next section.



This view, after unforshortening takes place, allows for clearances as well as vertical displacements in ladder rungs and handholds to be recognized using machine vision algorithms. It is also possible to obtain images of both the sill step and uncoupling lever from this view, although other views may be more effective for these recognition tasks. Using this angle, four cameras would be required, one for each corner of the railcar.



**Figure 7.5 Upward angled side view of railcar representing the optimal angle for viewing ladder, handholds, and the brake wheel**

Table 7.1 summarizes each of the camera views that have been discussed in this section. A check (✓) indicates that the safety appliance parameter listed in CFR Part 231 can be viewed and assessed from the given camera view.

Safety Appliance	CFR Part 231 Parameter	Camera View				
		Perpendicular Side	Overhead Perpendicular	Overhead Angled	Side Angled	Side Upward Angled
Side Ladder Rungs	Vertical Displacement Spacing	✓		✓	✓	✓
	Clearance			✓		✓
End Ladder Rungs	Vertical Displacement Spacing					✓
	Clearance		✓			✓
Side Handholds	Vertical Displacement Spacing	✓		✓	✓	✓
	Clearance			✓		✓
End Handholds	Vertical Displacement Spacing					✓
	Clearance		✓			✓
Brake Wheel	Clearance Deformation	✓	✓	✓	✓	✓
Number of Cameras Needed		1	1	2	4	4

**Table 7.1 Summary table of views considered in photographing safety appliances**

### 7.3 Camera Angle

In order for ladder rung clearances to be visible from the camera, it was determined that the camera should be located beneath the top of rail and aimed upward at the railcar's corner post. The camera is aimed toward the railcar at an angle of 45° relative to the track (Figure 7.6). This allows the center post to be in the center of the image, and ensures that the angles between the top chord and end post are equal on both the side and the end of the railcar providing a symmetrical image.

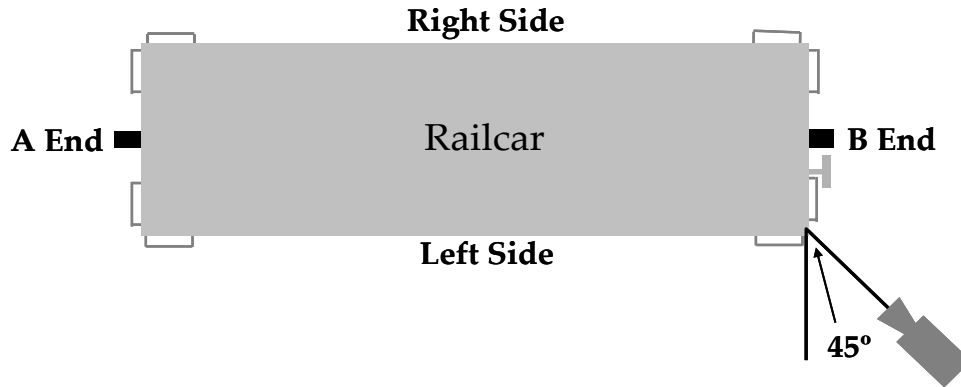

**Figure 7.6 Optimal camera angle relative to the track for the inspection of safety appliances using machine vision technology**

Next, the camera's location beneath the top of rail and resulting angle were determined (Figure 7.7). This angle is approximately  $6^\circ$  and represents only the camera's physical location below the top of rail, and not the angle formed between the camera and the camera target.

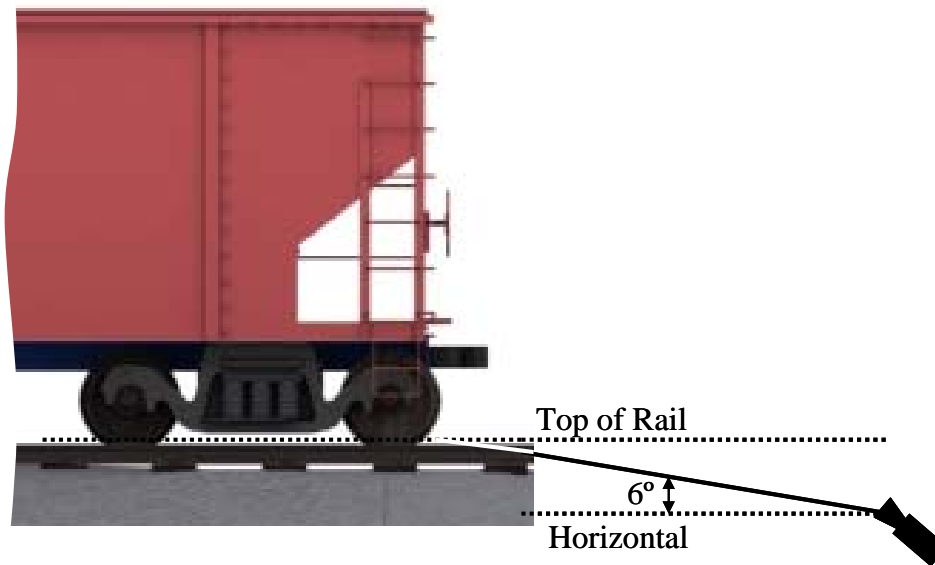

**Figure 7.7 Angle representing the physical location of the camera beneath the top of rail**

The locational parameters of the camera are given as angles instead of distances whenever possible. This allows use of different focal length lenses. In other words, a longer focal length camera would require the camera to be located farther from the track center, but remains at an angle of  $6^\circ$  below the top of rail.

The other critical angle associated with the camera installation is the angle formed between the center of the camera's target and a horizontal line extending from the camera's sensor (Figure 7.8). The exact angle of the target and camera was determined by obtaining images from many different camera angles and running the algorithm on the images to determine which led to the best identification of representative defects. This angle was determined to be approximately  $55^\circ$ . This places the center of the camera target above the center of the railcar to compensate for higher car types than the ones that are currently being evaluated. Additionally, this allows the top side and end ladder rungs to be viewed with the underside of the railcar's top chord as the background. If the rungs were aligned with the edge of the top chord it would complicate the recognition task.

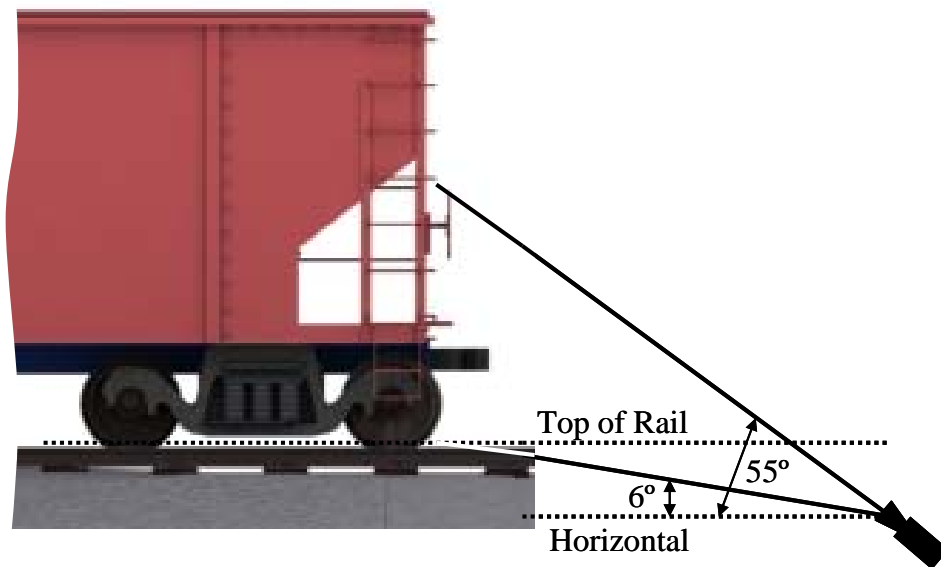

**Figure 7.8 Critical angles in locating the camera for machine vision inspection of safety appliances**

## 7.4 Image Acquisition System

A digital video camera with a ½” color Charge-Coupled Device (CCD) camera was used to record images. Initially, a 6-12 mm lens with a variable focal length was used. This lens provided adequate images if the track was elevated above ground level, however; it was not suitable at locations where the rails were close to ground level. As I gained experience in the field it became evident that use of a variable focal length lens made replication of a given focal length difficult. Consequently, I switched to a fixed, 6mm focal length lens which, along with better defined setup protocols, provided better repeatability.

In the initial, portable setup, the camera is mounted upside down below the tripod head, close to the substrate supporting the tripod, and remains outside the clearance plate for rail equipment (ORER 2005, Figure 7.9). The clearance plate represents the maximum cross section that railcars and their loads must fit within for unrestricted interchange.



**Figure 7.9 Temporary portable field setup for machine vision collection of safety appliance images**

Use of a resolution of 480x640 enabled the top ladder rung to be distinguished without being considered noise. The noise threshold for this recognition task is two pixels. Resolution refers to the number of pixels per inch, with a higher resolution resulting in greater detail available for algorithmic recognition.

Frames are generated at a rate of 30 frames per second and are converted to an AVI format. This frame rate ensures that an image will be captured within the tolerable window of 40 pixels relative to the center of the image under low speed conditions (Figure 7.10).

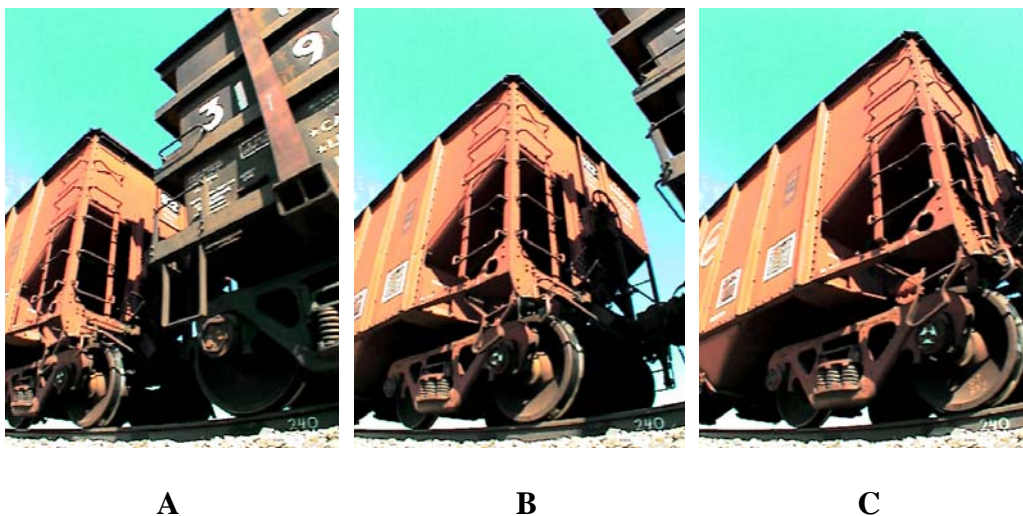

**Figure 7.10 Image sequence for one corner of a railcar showing, A) an image taken too early, B) at the optimal time, and C) too late**

### **7.5 Machine Vision Algorithm**

The goal of the initial machine vision algorithm is to detect ladder rungs, handholds and brake-wheels on high sided hoppers and gondolas, and to classify the detected appliances as 1) no exception taken, 2) deformed, but not FRA-condemnable, or

3) FRA defects. Subsequent algorithms will focus on the remaining appliances and car types.

The first algorithmic process after video collection is the extraction of frames from the video. After all of the frames are extracted from the initial video, it is necessary to select an optimal frame that provides the best view of a car passing by the camera. Note that in a video sequence the position of the moving car is displaced in each consecutive frame by a small but not necessarily constant amount due to fluctuating train speeds. In the optimal frame (Figure 7.10B), the car position is such that the two edges of the car's top chord meet at the center of the image (Todorovic 2005).

In the next module of the machine vision system, the selected frame is analyzed. Due to a foreshortening effect caused by the camera position and angle from which the railcar is viewed, parts of the car that are farthest away from the camera appear smaller and distorted (Todorovic 2005). Therefore, a perspective correction is conducted known as unforeshortening that yields two views of the car that each appear as if they were taken by two cameras perpendicular to the car's side and ends (Todorovic 2005, Figure 7.11). This procedure not only saves the cost of mounting two cameras, but more importantly provides the perpendicular view of the end of the car that an additional camera, irrespective of position, would be unable to obtain.

The perspective correction is done by homography, where all the points belonging to a specified plane are transformed so that the foreshortening effect is corrected (Todorovic 2005). The specification of the two planes in the image is done automatically by finding the intersection of the top chord of the car with the image boundaries. Six points on the railcar are detected as shown in Figure 7.11. Three of these points are

located along the top chord of the railcar. The other three points are located along the end and side sills of the railcar. The two planes are selected and are represented by points A-B-C-D and A-F-E-D shown in Figure 7.11. Once the planes are specified and split along line A-D which is drawn along the corner post, homography projects them onto the image plane.

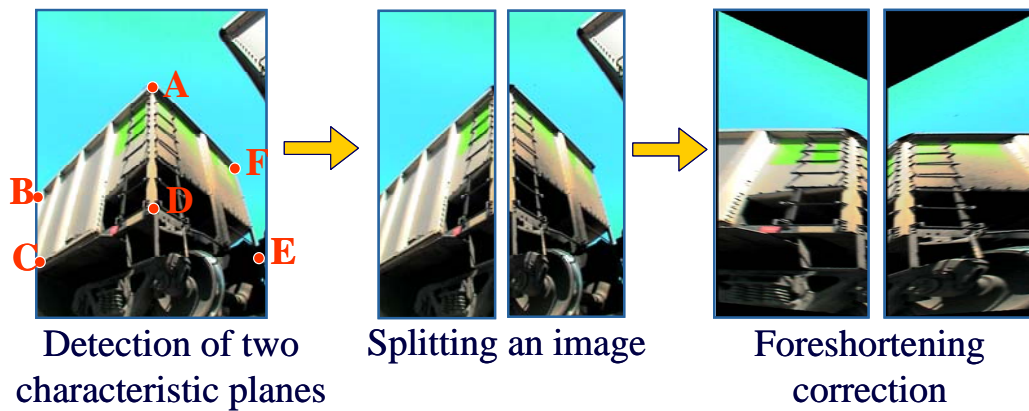

**Figure 7.11 Three primary steps in the perspective correlation process for an image**

Such corrected images are more amenable to detection and assessment of safety appliance condition. In the next module, each corrected part of the selected frame is analyzed to detect safety appliances. To detect ladder rungs, edges are detected using a Canny detector (Shapiro 2001, Figure 7.12) which detects edges within the image (Todorovic 2006). Edges represent a change in intensity within the image.



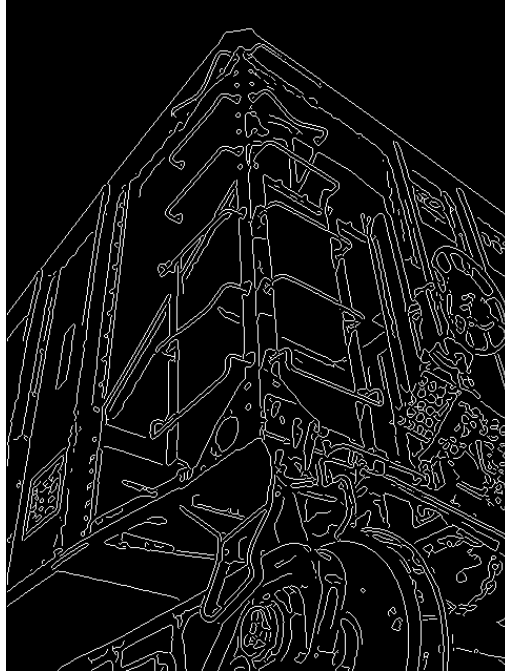

**Figure 7.12 Image of railcar after edge detection has taken place**

Starting from the top edge of the car, the algorithm searches for periodically spaced, horizontal, parallel lines to define the area where the ladder and handholds are most likely to be (Todorovic 2006). The straight-line edges in the specified area are classified as compliant (no exception) ladder rungs and handholds; the edges that are curves are classified as deformed appliances. Note that the algorithm correctly identified the deformation to the top and second from bottom side ladder rungs as well as deformation to the end ladder rung that is second from the top (Figure 7.13). Yellow indicates no exception and red indicates deformed safety appliances.

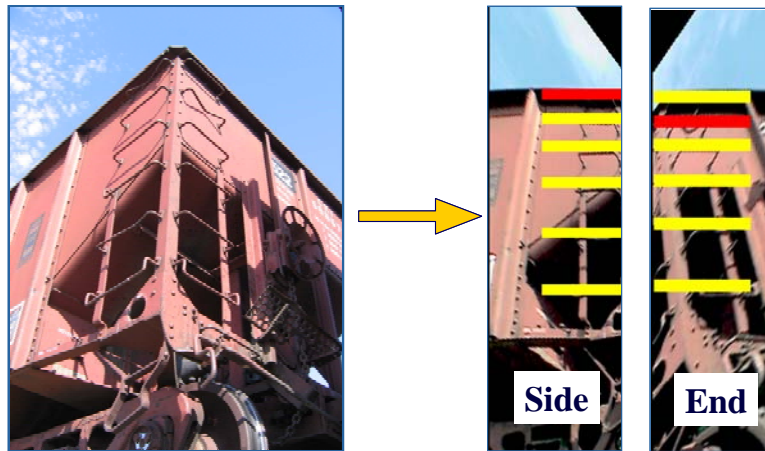

**Figure 7.13 Detection of ladder rungs and handholds on the side and end of a railcar**

Additional examples of detected ladder rungs and handholds are presented in Figure 7.14. The left images represent a newer gondola whereas the right images represent an older hopper car that is highly deformed. The car on the right posed additional recognition problems due to the horizontal parallel lines that are external ribs on the side of the car. The algorithm was successfully modified to detect these hoppers.



**Figure 7.14 Additional examples of detected ladder rungs and handholds**

Detection and assessment of a brake-wheel does not require the perspective correction because the appearance of the brake-wheel is sufficiently different from the background, thus direct analysis of the original image is satisfactory. The algorithm

matches the brake wheel to a set of ideal brake wheel templates developed based on known designs. The area in the image for which the correlation with the template yields the highest value represents the detected brake-wheel. If part of the detected area differs from the template it is classified as deformed (Figure 7.15).

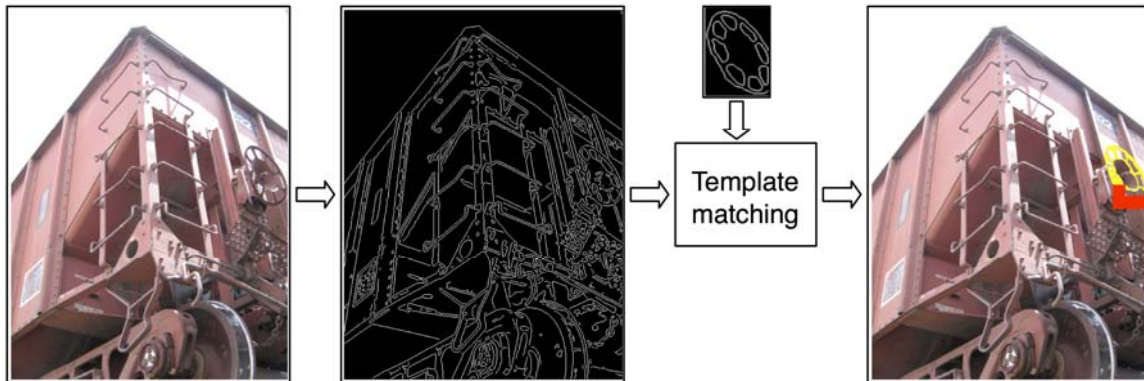

**Figure 7.15 Brake-wheel detection; yellow indicates no exception and red indicates deformation of the brake-wheel**

## 7.6 Frame Rate and Train Speed

For imaging the safety appliances considered in the initial phase of the project, the frame rate is set at 30 frames per second due to the camera parameters and the previously discussed camera view. Due to the angle at which the camera is located relative to the direction of travel of the train ( $45^\circ$ ), the camera's field of view images more of the train than it would if the image was captured perpendicular to the track (Figure 7.16). For any given sensor size and focal length of camera, the frame width is fixed if the distance from the lens to the object is known. Field of view calculators are available on the internet (Adome 2006) to calculate the distance, the focal length, or the size of the camera's field of view given that the remaining parameters are known. For this project, the 10.5-foot width of the camera's field of view provides an image of 14.8-feet of the side of train.

The algorithm can tolerate images taken within a window of 40 pixels; +/- 20 pixels on either side of the center of the image which represents 40/480 or 8.3% of the length of train captured in each image.

To determine the limiting train speed using the set frame rate, we must first know the maximum length of train that can pass between the capture of consecutive frames. This is calculated as  $8.3\% \times 14.8 \text{ ft} = 1.23 \text{ ft}$ . From this, the speed at which a train travels 1.23 ft in  $1/30^{\text{th}}$  of a second can be determined. This speed is 37.1 ft/sec or 25.3 mph. If railroad operations and inspection installation requirements necessitate recording at greater than 25 mph, the frame rate must be increased accordingly. For each doubling of the speed of the train, the frame rate must also double. In order to achieve a frame rate of 60 frames per second (double the current frame rate) more sophisticated cameras may be needed.

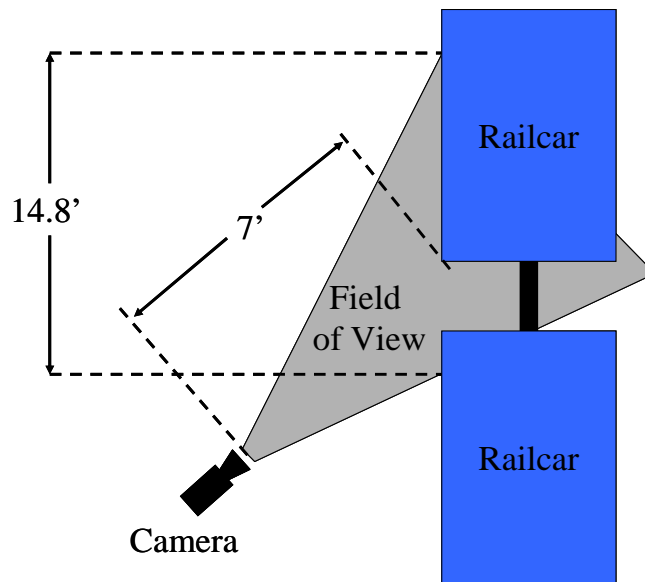

**Figure 7.16 Plan view showing the camera's field of view and the length of railcar captured during the imaging process**

## **7.7 Methods for Obtaining Images of Deformed Railcar Safety Appliances**

A large number of images of deformed safety appliances are needed to develop the learning algorithm. Because of the relatively low rate at which safety appliance defects occur, the acquisition of a sufficient number of these images would take a long time. To accelerate this process other collection methods are being pursued.

### *7.7.1 Manual Deformation of Railcar Safety Appliances*

One way that images of deformed safety appliances were obtained was to damage an open-top hopper car under controlled conditions at the Transportation Technology Center (TTC) Facility for Accelerated Service Testing (FAST) near Pueblo, CO. Damage representative of what is often encountered in the field was inflicted on one of each safety appliance on the railcar (Figures 7.10, 7.13, and 7.15) using hammers, chains, and a forklift. After the car was damaged, it was operated around the FAST Track as part of a 15-car test train made up of open-top hoppers and gondolas. Digital video of the train was recorded at two locations on the FAST loop track to take advantage of the ambient lighting conditions.

### *7.7.2 Three Dimensional Modeling of Railcar Safety Appliances*

Another method of generating images of safety appliance damage is through the use of a virtual model that allows for modeling of safety appliance deformation 1) under varying lighting conditions, 2) on multiple car types, and 3) from differing camera views and angles.

Autodesk's® 3DS MAX 8 computer modeling software was used to create a three dimensional model of an open-top hopper car. 3DS MAX 8 allows the user flexibility in depicting different camera views and angles, as well as in depicting realistic lighting conditions. Additionally, the program provides a means of generating both still images and AVI files of the railcar model. A comparison of an actual camera and an image from the 3D model is shown in Figure 7.17.

#### 7.7.2.1 Lighting and Camera Specifics

Within 3DS MAX, cameras can be located at any user-defined location within the model space. The resolution of the camera is set by the user and the field of view is set by changing the camera's distance from the railcar. The model allowed me to determine the optimal camera angle once the view was selected. This was accomplished by running the algorithm on numerous images taken from angles below the top of rail. All of the images tested were at a 45° horizontal angle with respect to the track.

#### 7.7.2.2 Model Uses

Visual learning is being used to categorize deformation to a railcar's safety appliances. Using this approach, it is necessary to gather hundreds of images representing defective safety appliances to teach the algorithm the difference among the various defect classes. Gathering these images in the field is tedious and labor intensive. Each time a train is imaged in the field we obtain a large number of images of which only a small percentage, one percent or less, contain safety appliance deformation. Using the model, it is not only possible to simulate the railroad environment lighting, but also

generate hundreds of types of deformation that would be difficult to gather by imaging real trains. Information regarding typical types of safety appliance deformation will be gathered from railroad mechanical personnel ensuring that the algorithms will be tailored to the recognition tasks that it will be required to perform.

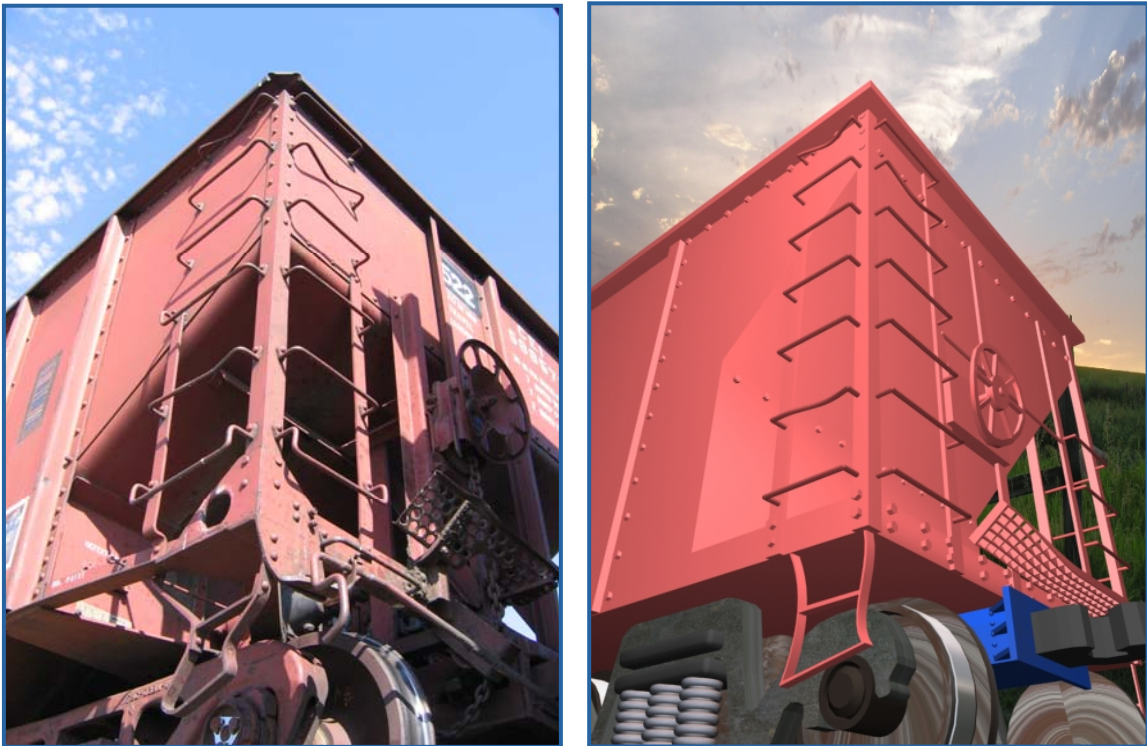
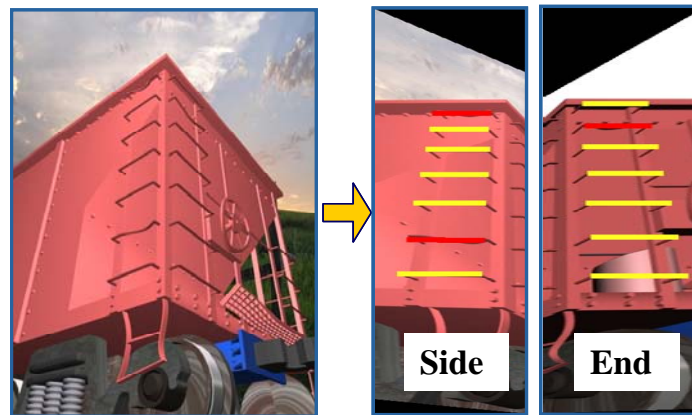

**Figure 7.17 Views of a railcar after deformation was inflicted in a controlled environment (left) and the corresponding 3D model showing the deformation (right)**

The use of a virtual model increases the robustness of the machine vision algorithm by allowing generation of images under varying lighting conditions. Of the many lighting types provided within 3DS 8, two types are of interest for this project. The first is omni light, and consists of light having an intensity that is inversely proportional to the distance between the light and target. Omni light is the best representation of what an artificial spotlight would provide for this application. Secondly, sky light is analogous to sunlight in that the intensity does not decrease as the distance from the light source to

the target increases. If the model is verified on one car type it should be able to be extrapolated to be used on other car types, saving time and expense compared to field work.

Figure 7.18 shows the algorithmic result from the model car. The second ladder rung from the bottom is not an FRA defect, but does have deformation. The sensitivity of the algorithm can be adjusted to either recognize or filter out these types of minor deformation. Eventually, use of visual learning will enable categorization of this as deformed, but not an FRA violation.



**Figure 7.18 Validation of algorithms on the model image which replicates the deformation seen in the actual image in Figure 7.17**

Another use of the model is to predict the lighting conditions at a given location given the coordinates (latitude/longitude), track orientation, and time of year. This helps determine the best camera location when planning field visits to capture images during the research stages of this project. It may also aid in planning the design of permanent field installations.



### 7.7.2.3 Model Limitations

The limitations of the computer model should be recognized and considered as safety appliance recognition algorithms are developed. All edges of the railcar will appear crisper than the actual edges on the car. This gives the Canny detectors an easier task than will actually occur due to rust, minor irregularities and other aspects inherent in the railroad environment. The surface of the simulated railcar can be altered to reduce this effect.

## **7.8 Challenges and Considerations in using Machine Vision to Inspect Safety Appliances**

There are many considerations and limitations that must be understood with respect to the machine vision inspection of safety appliances on railcars. These should be recognized and considered throughout the process of designing an efficient, safe, and economic machine vision system for inspection of safety appliances.

First, railroad car inspections include the inspection of a number of other items in addition to safety appliances (See Chapter 3). The more inspection capabilities that a given site has, the better the benefit-cost ratio associated with its installation will be because the fixed cost of the installation can be distributed across more technologies. Thus, the chances of a given technology being economically feasible will be increased. The current trend is for installations to combine several machine vision technologies for inspection of a variety of mechanical components.

Secondly, car inspections should involve a great deal of interaction between the carman and car. There are challenges to applying machine vision to many of these tactile inspection processes given that machine vision is a form of visual inspection. These

interactions could consist of the carmen bending down to look under the car body for a crack in the center sill or using a hammer to beat on a ladder rung to check for securement. Based on field observations, carmen do not inspect each and every appliance by tactile means. This would be far too involved for inbound car inspections and is mainly used as a means of following up on cues from their visual inspection. Cues should be identified that could aid a visual inspection system in detecting defects that would normally be identified by tactile inspection methods. One cue could be the deformation of a safety appliance, especially certain types that could signify poor securement. Another indication of poor securement could be a rust streak from the bolted connection between the safety appliance and the car body (Smith 2004). This would require additional camera views and possibly a higher resolution than the 480x640 currently used in order to ensure that rust at connections farthest from the camera was not in the range of noise.

Parallel to this discussion, consideration should be given to possibility of changes to CFR Part 231 and the inspection requirements therein. This would involve a careful analysis of the functional and safety requirements of each safety appliances. This knowledge would be integrated with an understanding of the attributes of machine vision (and other technologies) to develop new design and/or the specific inspection requirements that enhanced both safety and efficiency.

Finally, the system must be robust to a variant of ambient lighting conditions in order to justify the investment of such a system. Lighting is commonly one of the greatest challenges in machine vision systems (Shapiro 2001). Machine vision systems are sensitive to changing light conditions that pose threats to even the most refined

algorithms when extracting critical parts of a given image. Oftentimes, lighting must be controlled by providing shelters or some means of artificial lighting. While this matter may be accomplished with relative ease on an assembly line, it is non-trivial to adapt in the railroad environment. For example, in the context of our current work, there is a large area under the slope sheet on both ends of hopper cars that appears dark under many lighting conditions. This area provides the background for the ladder and handholds. Changing lighting conditions can cause the handholds to become completely undetectable to the camera as they blend with the dark area under the slope sheet. Another example relevant to this application occurs when the top chord of an open-top gondola or hopper shadows the top ladder rungs during a large portion of the day. In many circumstances artificial lighting will act to normalize the range of lighting conditions encountered in an outdoor environment.

## **7.9 Other Methods of Detecting Safety Appliance Defects**

### *7.9.1 Comparison of Opposite Corners*

A potentially elegant alternative to developing algorithms to detect deformations was considered. This approach would take advantage of the symmetry of opposite corners of a railcar (Figure 8.1 explains that  $AR = BL$  and  $AL = BR$ ). Images of the opposite corners of a railcar would be recorded and overlaid on top of one another, and any differences in the safety appliances would be assumed to be deformation (Figure 7.19). Unfortunately, this method proved to be less efficient than anticipated. Obtaining the perfect alignment needed for image comparison was time consuming and appears to involve much tighter tolerances regarding image perspective and composition than the

method previously described (Todorovic 2006). If the idea were to be implemented, the images would have to be aligned dynamically (Todorovic 2006).



**Figure 7.19 View of both the BL and AR corners of a covered hopper demonstrating the ease as to which the two opposite corners can be compared**

This alignment would involve first selecting the same characteristic points on the railcar as is needed before perspective correction; three along the top chord and three along the end and side sill of the railcar (Figure 7.20).

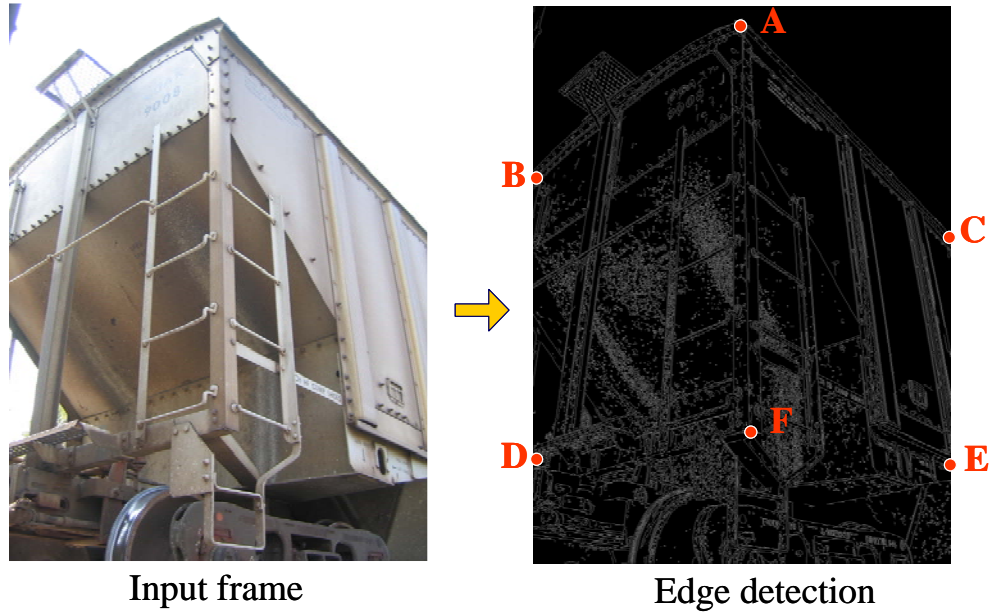

**Figure 7.20 Example images before and after edge detection algorithms were run on the image**

This would be due to the many sources of error that can be introduced in the railroad environment. The image would have to be captured while the corner post was within an extremely small window of tolerance at the center of the image. A corner post that is not in the center of the image changes the relative location of the characteristic points on the top chord and base of the railcar that are selected prior to matching being performed on the image. Additionally, each fraction of a degree that a camera is off relative to the camera that is capturing its counterpart image could result in the top of the image being shifted off by several inches, further increasing the time needed to analyze the image. As can be seen in Figure 7.21, the BR and AL corners do not align fully for the reasons described above. The blue lines represent the BR corner and the red lines represent the AL corner.

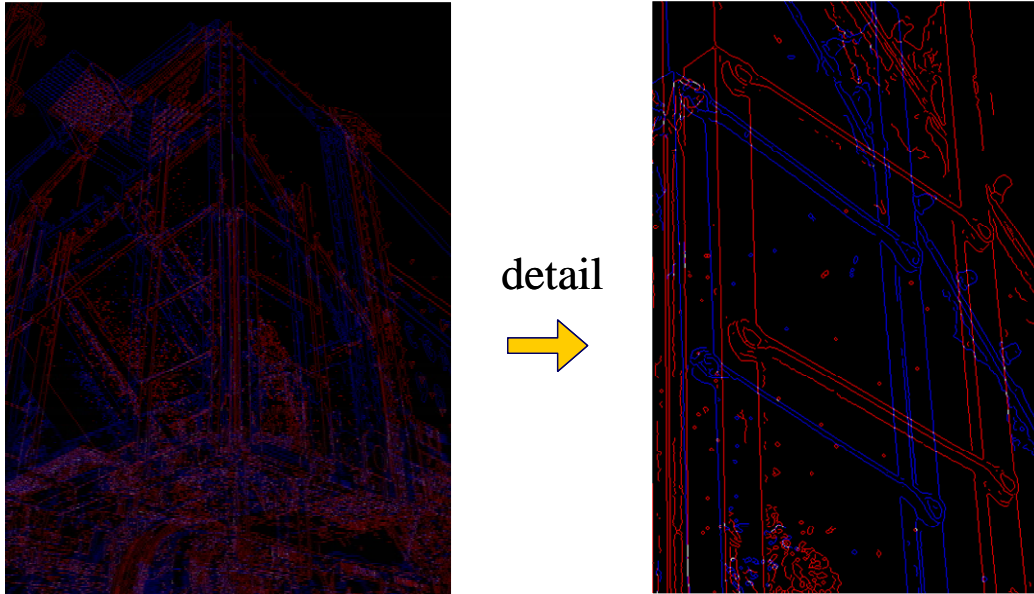

**Figure 7.21 Example of overlaid BR and AL corners of a covered hopper car.**

In conclusion, the computational time needed to perform matching exceeds the amount of time needed to analyze each individual image. Furthermore, learning algorithms would still need to be developed to analyze and characterize appliance deformation, so no effort would be saved in the development of algorithms.

#### *7.9.2 Analysis of Shadows to Determine Ladder Rung and Handhold Clearance*

One of the most critical, and consistent, safety appliance parameters is the need for two inches of clearances between handholds and ladder rungs and the car body. This clearance is not visible from any location other than above or below the railcar. One means by which the rung clearance would be visible is through the use of artificial lighting mounted above or below the train and a camera located perpendicular to the tracks. Depending on the intensity of the light, shadows will be cast on the car body and the image would contain two lines for each ladder or handhold. Additional shadows would be cast from the sun, and the algorithm would have to be capable of taking the

time of day and geographical location into consideration to determine whether or not the visible shadow-depicted clearance is less than 2". In summary, this method of determining ladder rung and handhold clearance would allow for the ladder rung to be inspected for deformation in two planes from a single camera view. It is the author's opinion that this method is less reliable than the perspective correction method discussed earlier.

## **7.10 Future Work Prioritization**

### *7.10.1 Prioritization of Additional Safety Appliances*

Additional appliances should be prioritized through the use of two types of data. First, FRA inspection data should be used to determine the appliances that have the largest numbers of defects. Secondly, Class I railroad data should be used to determine which appliances result in the highest percentage of bad orders. Ideally, the railroad data would be taken from a variety of locations throughout the industry to ensure that local car handling techniques and car types do not give undue weight to certain types of safety appliance problems.

### *7.10.2 Prioritization of Additional Car Types*

There are several means by which additional car types can be prioritized. One method would be to use Class I railroad bad order data. These data are generally broken down by car type and would provide a guide as to which car types were bad ordered at the highest rate. FRA defect data are not useful in prioritizing car types because the type of car is not recorded in the FRA Inspection Database (FRA 2005).

Another method that could be used to prioritize car types is use of Wheel Impact Load Detector (WILD) data. WILD data shows the number of times each car passes a WILD installation during a set period of time (Figure 7.22).

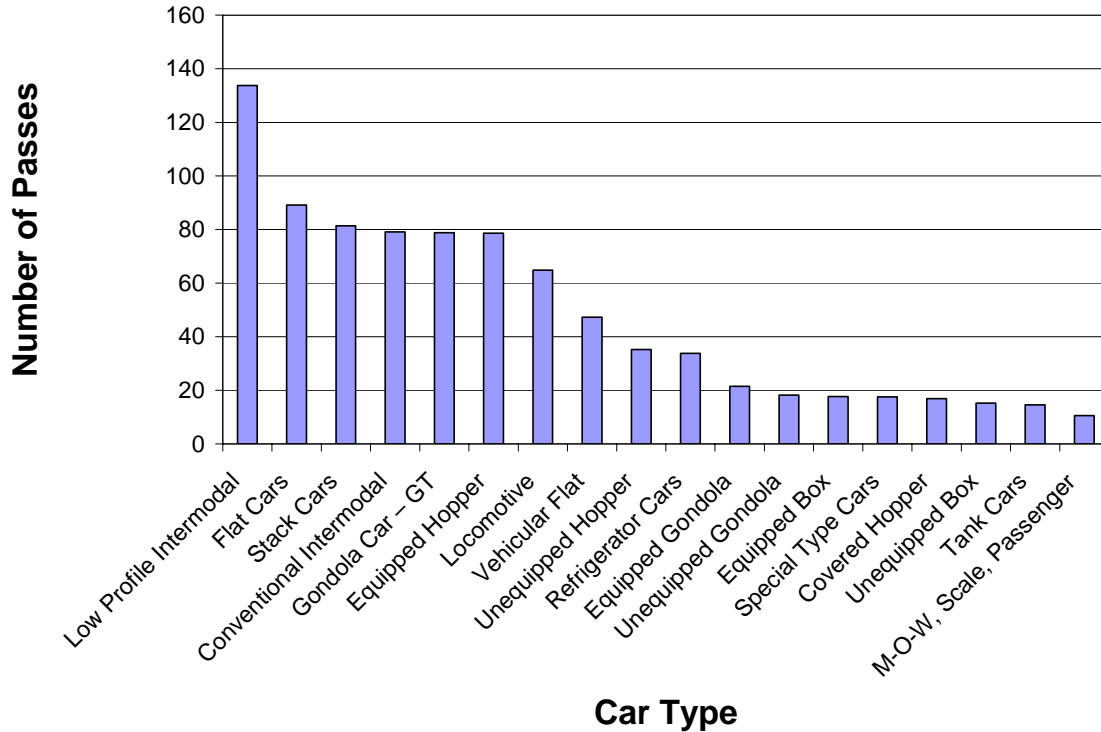

**Figure 7.22 Average number of visits to WILD sites between October 2004 and November 2005**

Equipped gondolas, unequipped gondola, and unequipped hoppers have had safety appliances successfully identified on them using machine vision algorithms. The data in Table 7.2 indicates that low profile cars are passing by the WILD detectors most frequently.



<b>Car Type</b>	<b>Code</b>	<b>Mean Passes</b>
Equipped Box	A	17.64
Unequipped Box	B	15.22
Covered Hopper	C	16.86
Locomotive	D	64.87
Equipped Gondola	E	21.49
Flat Cars	F	89.12
Unequipped Gondola	G	18.16
Unequipped Hopper	H	35.20
Gondola Car – GT	J	78.77
Equipped Hopper	K	78.63
Special Type Cars	L	17.58
M-O-W, Scale, Passenger	M	10.59
Conventional Intermodal	P	79.07
Low Profile Intermodal	Q	133.76
Refrigerator Cars	R	33.76
Stack Cars	S	81.36
Tank Cars	T	14.52
Vehicular Flat	V	47.31

**Table 7.2 Car Types and Codes showing the average number of passes by a WILD site between October 2004 and November 2005**

A drawback of using these data is that they may not be representative of the railroad network as a whole. There may be a tendency to locate WILD sites on lines with high amounts of coal or intermodal traffic, since those lines are some of the highest density routes. If this were the case, there would be a false sense that open-top hoppers, open-top gondolas, flat, and well cars are being utilized more than other car types.

Another means of prioritizing car types is through the use of AAR (2005) data on car miles for each car type found in the AAR’s Analysis of Class I Railroads (Figure 7.23). Although the categorization used by the two sources differs somewhat the data generally agrees with the WILD data with one notable exception. The car mileage data show that covered hoppers traveled more miles than any other car type whereas they were

ranked 15<sup>th</sup> in frequency among car types passing WILD sites. Intermodal flats and equipped gondolas ranked 2<sup>nd</sup> and 3<sup>rd</sup> which is similar to the WILD data. These data are also consistent with the hypothesis that WILD sites are located on routes that see high volumes of coal and intermodal traffic.

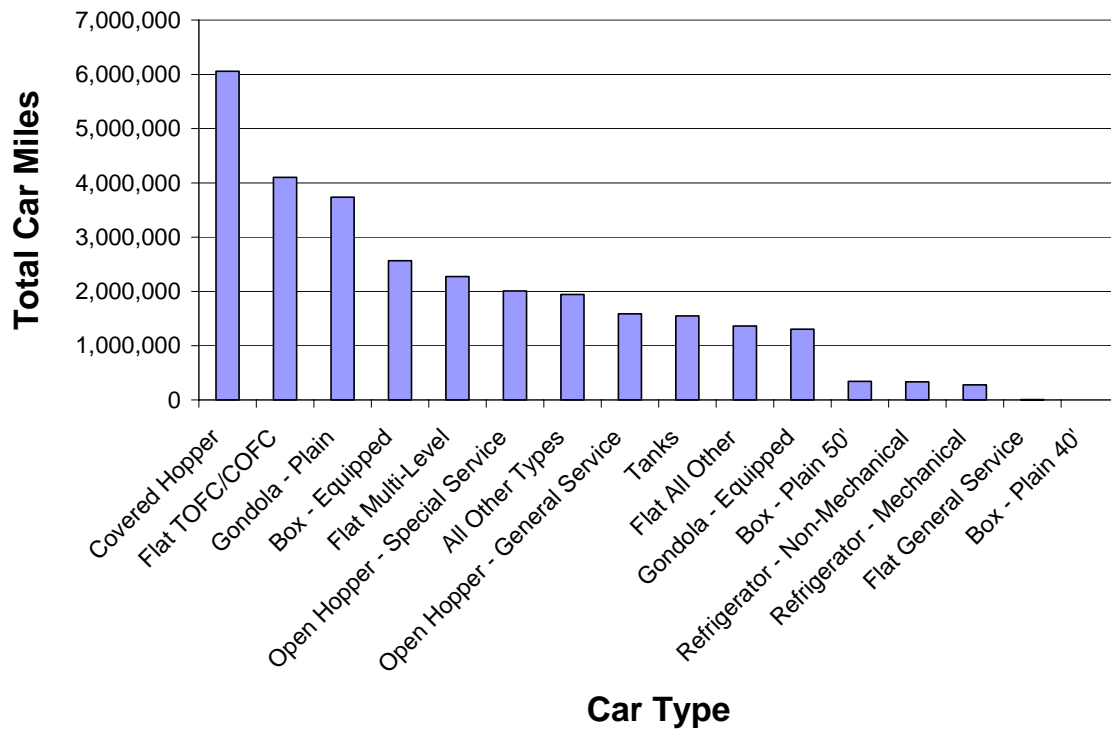

**Figure 7.23 Car miles traveled by car type in 2004 (AAR 2005)**

In summary, a combination of railroad bad order data, WILD data, and AAR car mileage data should be used to determine which car type(s) algorithm development should focus on to provide the most benefit to the railroads as resources become available for development and implementation of this technology.

## **CHAPTER 8: INTERIM APPROACH TO MACHINE VISION INSPECTION OF RAILCAR SAFETY APPLIANCES**

Development of a fully functional machine vision safety appliance inspection system is likely to take a number of years. However, there is an interim approach that would have the dual benefit of improving the efficiency of railcar inspection in the short term, and accelerating the longer term development of machine vision safety appliance inspection technology.

### **8.1 Overview of Interim System**

In this interim system, videos of trains would be recorded using a digital video camera in the same manner used in the tests already described. The current image selection algorithms would be used to extract optimal images from the frame sequence that provide the best view of safety appliances and their respective parameters outlined in Part 231. Once the optimal images are extracted, they would be analyzed manually by carmen viewing a computer monitor who would note damage to safety appliances. The carmen would flag any railcars they suspect of having defects for follow up inspection, repair in the yard, or bad ordering cars straight to a repair track.

### **8.2 Installation**

The installation should be at a location that allows trains to be recorded as they enter a yard. If located outside the yard and if the train speed will be higher than 25 mph then a frame rate greater than 30 frames per second would need to be used. The time needed for mechanical personnel to view the images, interpret the information, and

develop a method of handling the incoming train must be considered as well as developing a process for handling any possible defects detected. The relay of information may simply include a carman printing out a sheet with a list of the cars and their respective defects, or the relay could be accomplished by downloading this information to a PDA for use by a carman. Once the location is selected based on the above factors, four cameras would be needed to obtain images of the four corners of the railcar (Figure 8.1).

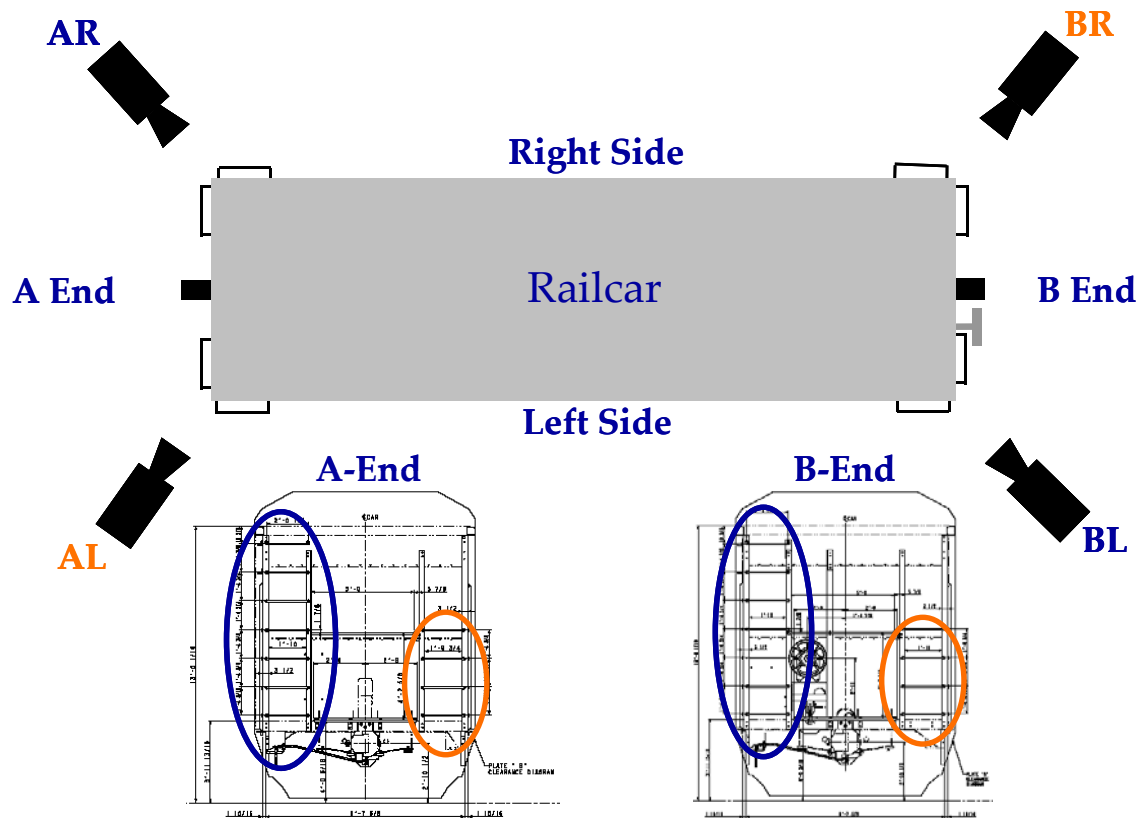

**Figure 8.1 Camera views for interim machine vision installation of railcar safety appliances**

As the four cameras collect the images they will be saved in AVI format. After the video is collected the frames must be extracted before the optimal images will be selected from the image sequence. The optimal image for a given corner of a railcar is

the one in which the corner post is in the leading position and vertically oriented in the center of the image.

### 8.3 Image Analysis

When the four optimal images are selected for each railcar, they should be grouped into two pairs for each car. These pairs represent the AL and BR corners and the AR and BL corners. These respective pairs of corners are identical in terms of their safety appliance configuration with the exception of the presence of the brake wheel in the B-end views of the car (Figures 8.2, 8.3, and 8.4).

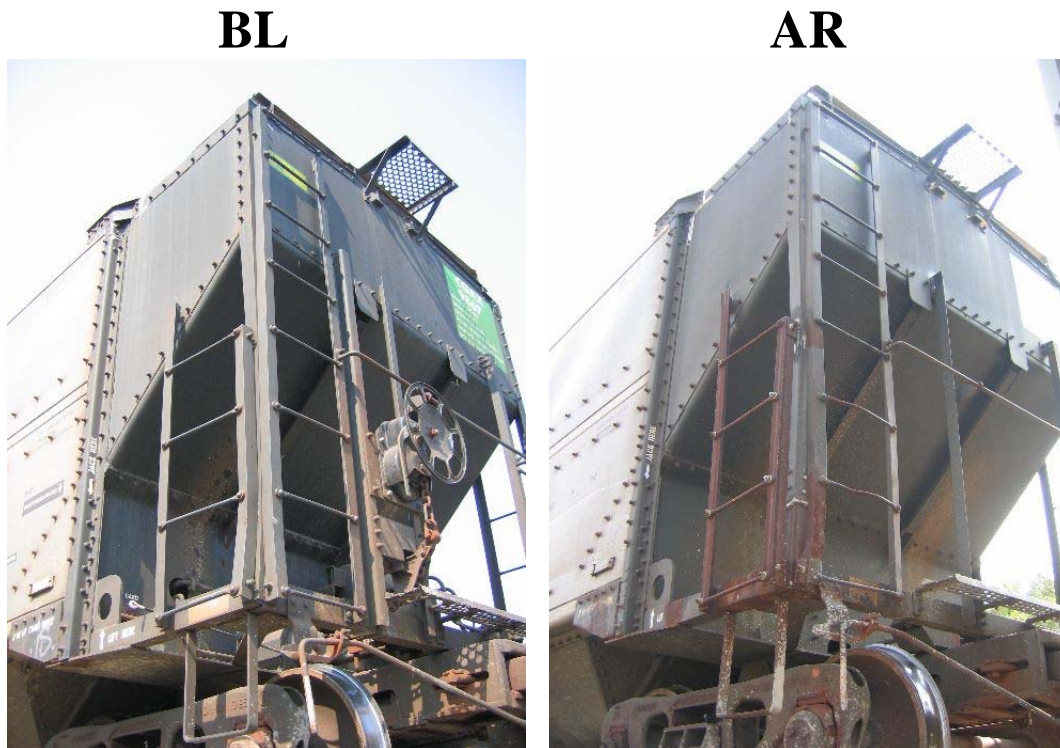
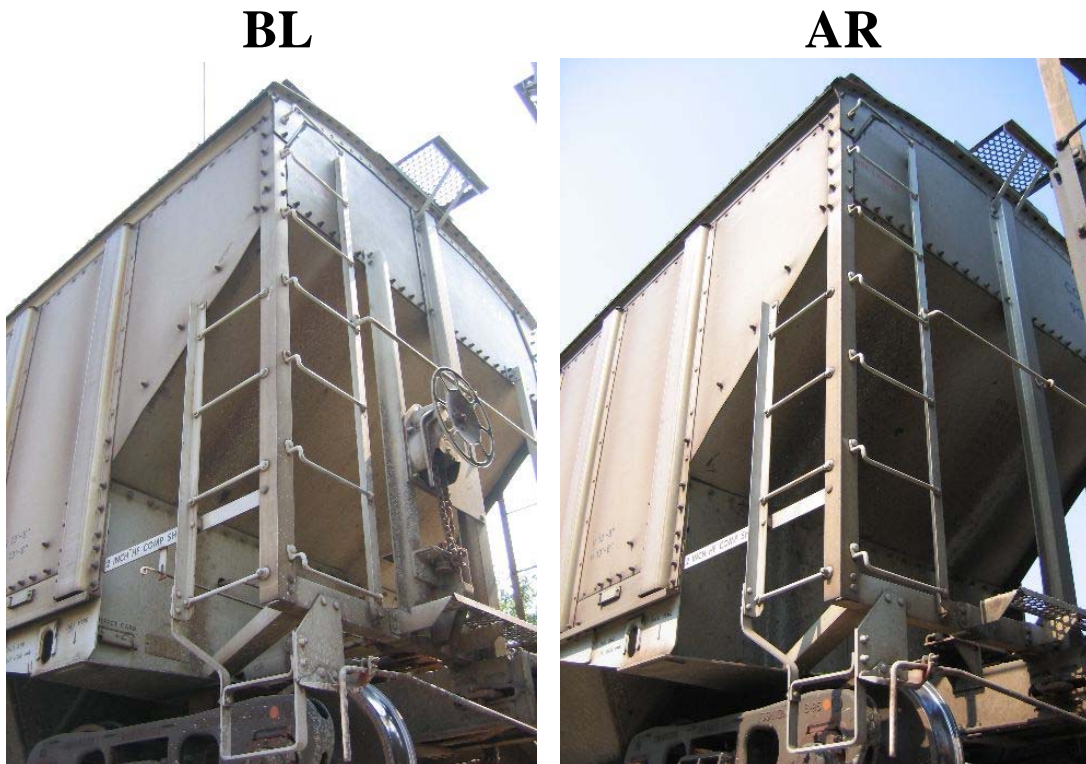

**Figure 8.2 View of the BL and AR corners of a hopper demonstrating the ease of comparison of like elements of the safety appliances**

Most cars have two corners with ladders and two corners with only handholds or modified ladders. Once the two like images are grouped side by side, they can be

examined and easily compared by carmen. In Figure 8.2 it is evident that the AR corner of the car has had extensive repairs made on its side ladder although there are no safety appliance defects on either corner. Carmen will be looking for aspects of the railcar corners that look different in the two images rather than looking at each corner separately and searching for defects. Most cars will be similar to Figure 8.3 in that there is no deformation and the two corners will appear alike.

Simultaneous viewing and comparison of like images may improve both the accuracy and speed of safety appliance inspection. The interim system employs the image acquisition hardware, but retains the human brain as the processor to interpret the images. As such, it could be considered as a technological aid to carmen performing inspections as discussed in Chapter 5.



**Figure 8.3 View of the BL and AR corners of a hopper showing no deformed safety appliances**

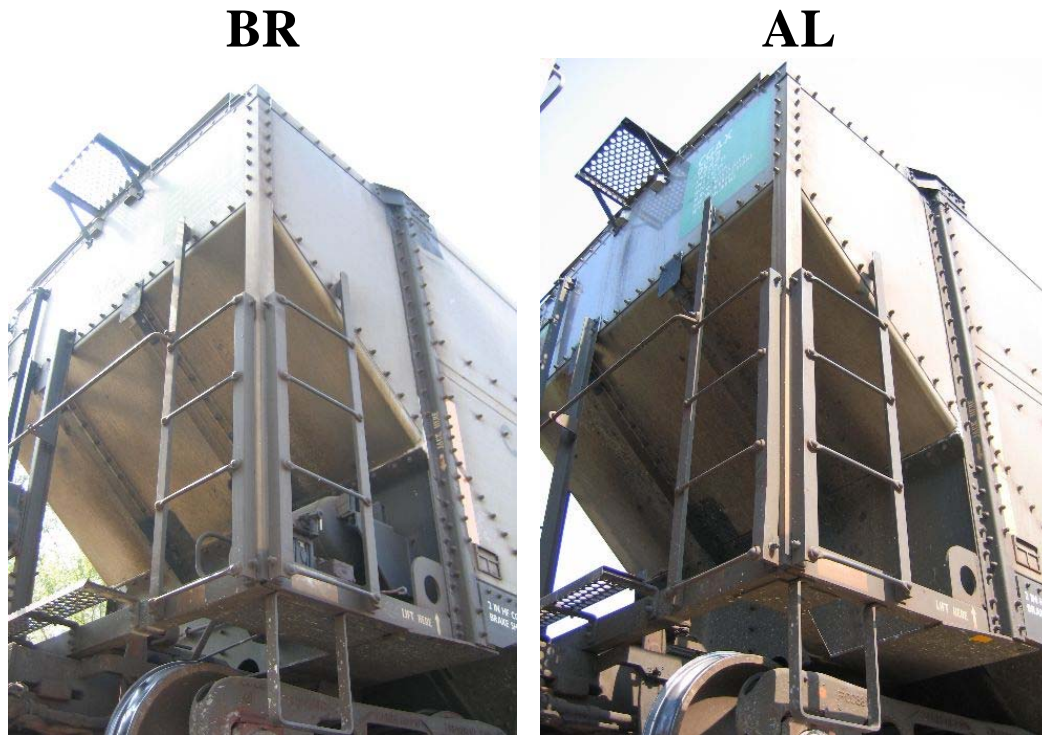

**Figure 8.4 View of the BR and AL corners of a hopper showing no deformed safety appliances**

An advantage of the interim installation is that it allows like corners to be simultaneously compared from identical viewing angles which is not possible with the current inspection process.

As with the final system, one of the challenges to an interim system such as described here involves lighting. There are often instances when the top chord of a gondola or hopper casts a shadow on the upper ladder rung and other instances when the ambient lighting is not adequate. In order for the interim installation to be cost justified artificial lighting would need to be incorporated to allow for operation 24 hours per day and under a variety of lighting conditions. Among the advantages of the system is that carmen will be able to observe the flow of images from a location, protected from the

elements and isolated from hazards. This might lead to a reduction in certain types of injuries that occur in yards

As mentioned above, another benefit to an interim machine vision system is that it will provide a flow of images that are needed to train the algorithms for the fully functional, automated, machine vision safety appliance inspection system. Currently, the vast majority of safety appliance images are not in violation of CFR Part 231, but as discussed in Chapter 7, training the algorithm will require thousands of images of deformed and defective appliances to be captured. An interim installation such as described here would provide that flow of images and at the same time provide near-term benefit to railroads by improving the efficiency, effectiveness, and possibly the safety of the current inspection process.



## **CHAPTER 9: SAFETY APPLIANCE PARAMETERS FOR MACHINE VISION DETECTION**

### **9.1 Overview of Parameters**

Safety appliance specifications for hopper cars and high-side gondolas with fixed ends are examined in depth in this chapter in the context of inspecting safety appliances using machine vision technology. Hoppers and gondolas are being examined because they are common car types, and there are only minor differences separating them from the other car types in terms of their safety appliance arrangement. The requirements for hopper cars and high-side gondolas can be found in §231.2 of Part 231 (FRA 2004b). High-sided cars are ones in which the sides extend more than 36” above the floor of the car (FRA 2004b). Photographs, drawings, and diagrams of safety appliances will be used to illustrate the parameters mentioned within §231.2. At times, this section paraphrases Part 231 (FRA 2004b), then builds off of the Safety Appliance Standards for a more in-depth explanation of the specific parameters within the standards.

Additionally, machine vision challenges for each appliance parameter will be considered. These challenges pertain to the determination of the angle from which to view the appliances as well as optimal illumination of the appliances. Illumination should reveal all parameters associated with the safety appliance instead of merely illuminating the appliance. For example, if a ladder rung is illuminated but the clearance between a ladder rung or handhold and the car body is not visible then compliance of the safety appliance to Part 231 is not known.

As previously discussed, Part 231 addresses many aspects of safety appliances and the relevant parameters found there can be divided into either quantitative or qualitative. For the most part, a machine vision system, like car inspectors who currently perform car inspections, would focus on the quantitative parameters. These quantitative parameters consist of the various distances (length, spacing, areas, and clearances). Qualitative parameters primarily pertain to material types and there is little need or use for a vision system to detect these parameters. A vision-based system should be capable of monitoring the quantitative parameters covered in the safety appliance standards. These quantitative parameters can be subdivided into two categories; design and dynamic parameters.

Design parameters are ones that should have been met when the car was built or rebuilt. In those instances of design parameters that were not met when cars were built FRA inspectors generally do not take exception to these violations if they have not caused a problem as discussed in Chapter 3. As new cars are designed, the safety appliance aspects of the car must be approved by the FRA prior to construction of the car as a part of a sample car inspection (FRA 2004a), so there is little chance that new cars are being constructed with safety appliances that violate FRA regulations. An example of a design parameter would be the length of a ladder rung. It is highly unlikely that this aspect of a ladder rung could be damaged to such an extent that it would violate CFR Part 231.

Dynamic parameters are ones that are most likely to be violated during the everyday movement of the railcar. These parameters were determined through field visits in which Class I railroad mechanical management and carmen identified safety

appliance parameters that were typically encountered in the yard and repair facilities. Unlike ladder rung length, there is a chance that the required 2” clearance between the ladder rung and car body can be altered as a car is moved.

For each safety appliance, the dynamic parameters are identified with red text boxes and arrows, and the design parameters are identified by blue text boxes and arrows.

## 9.2 Handbrake

The handbrake is used to manually apply the brakes on a railcar and basically serves as a “parking brake”. The brakes are applied by turning the hand brake wheel, which, through a series of chains and rods, apply force to the brake shoe against the tread of the wheel. Examples of hand brakes, brake wheels, and their configuration are shown in Figures 9.1 and 9.2.



**Figure 9.1 Images of the brake wheel**

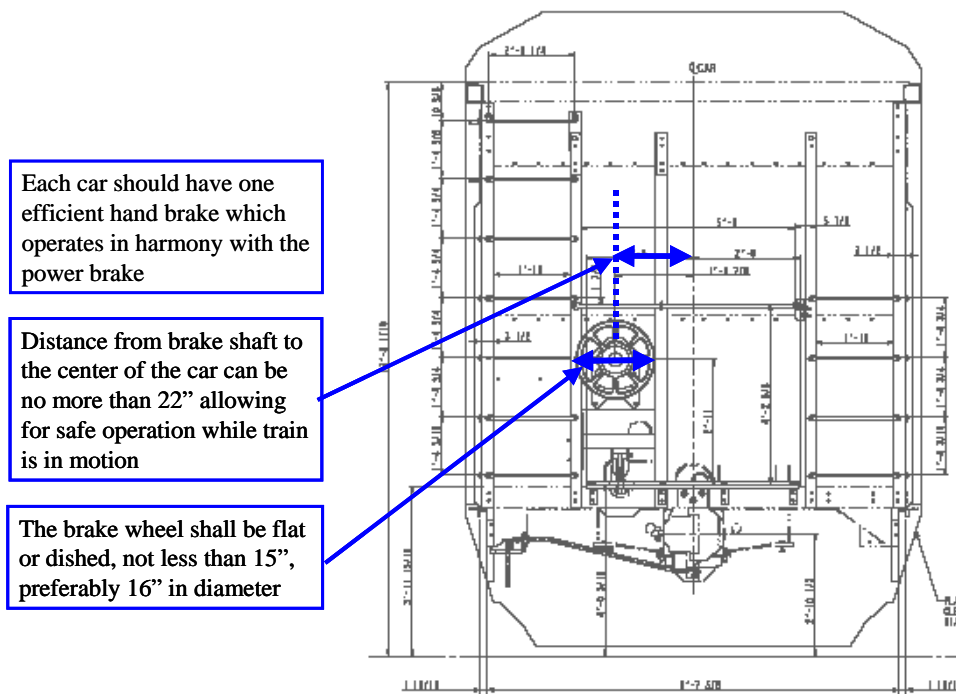

**Figure 9.2 Profile view of a common brake wheel design**

### *9.2.1 Handbrake Design Parameters (FRA 2004b)*

One efficient handbrake must operate in conjunction with the power brake providing the same degree of safety as is shown on Plate A or that is specified in §231.27 (Box and other house cars built or placed in service before October 1, 1966). The brake shaft shall be constructed out of steel or wrought iron not less than 1-1/4" in diameter. The brake wheel shall be made of malleable iron, wrought iron, or steel and can be dished or flat. The brake wheel shall be not less than 15", preferably 16" in diameter (Figures 9.3 and 9.4). The handbrake should be located so that it can be safely used while the car is in motion. The brake wheel should be at the end of the car no more than 2" from the center of the car. The top brake shaft supports shall be fastened with not less than 1/2" bolts or rivets. A brake shaft step shall support the lower end of the brake shaft. The brake shaft shall be arranged with a square fit at its upper end to secure the hand brake wheel, with the square fit being no less than 7/8 in<sup>2</sup>. The square taper should be nominally 2" in 12". The brake chain shall be of no less than 3/8" wrought iron or steel chain with the link on the brake rod end of not less than 7/16" that is secured on the brake brake-shaft drum by not less than 1/2" bolts. Lower end of the brake shaft must be

provided with a trunnion no less than  $\frac{3}{4}$ " in diameter extending through the brake-shaft step and held in operating position by a suitable cotter or ring. The brake-shaft drum shall be not less than 1-1/2" in diameter. The brake ratchet wheel shall be secured to the brake shaft with a square fit of no less than 1-5/16". Brake ratchet wheel shall be no less than 5-1/4" in diameter and must have no less than 14 teeth. If the brake wheel ratchet is more than 36" from the brake wheel a brake wheel supports shall be provided fastened with  $\frac{1}{2}$ " bolts or rivets. The brake pawl shall be pivoted upon a bolt with a minimum diameter of 5/8", with a trunnion secured by no less than  $\frac{1}{2}$ " bolt or rivet, with a rigid connection between brake shaft and pivot of pawl. The brake wheel shall be held in place by a nut on the extended end of the brake shaft that is no less than  $\frac{3}{4}$ " in diameter with the nut riveted. The brake wheel is arranged with a square fit for brake shaft in the hum of wheel; taper of said fit, nominally 2-1/2".



**Figure 9.3 Brake wheel parameters**

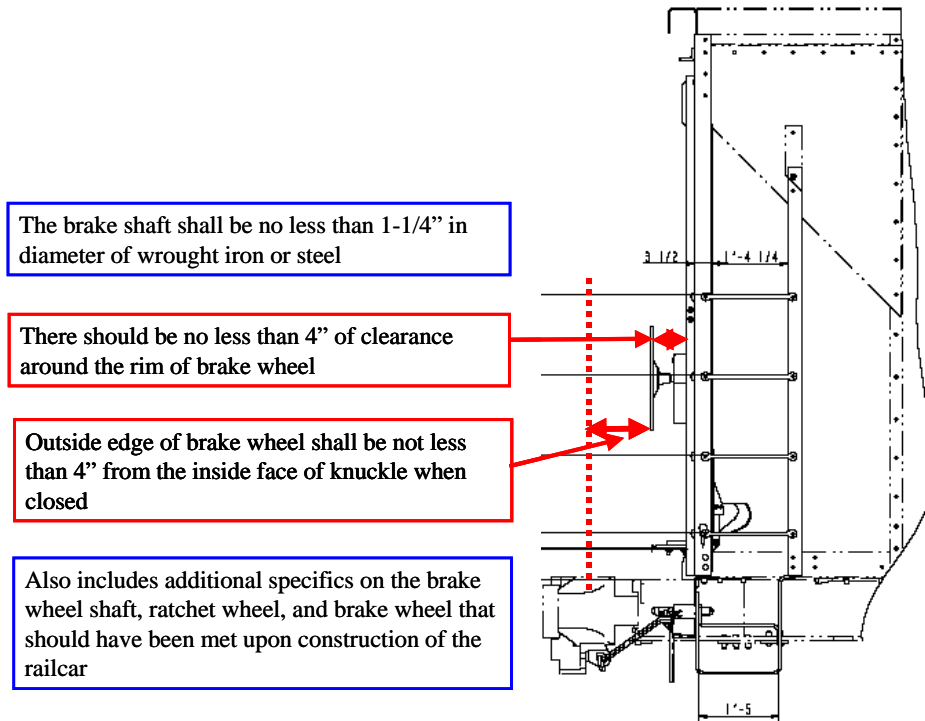

**Figure 9.4 Additional brake wheel parameters**

### 9.2.2 Brake Wheel Dynamic Parameters (FRA 2004b)

The rim of the brake wheel should have no less than 4" of clearance over its entire 360° circumference. The outside edge of brake wheel shall be no more than 4" from a vertical plane passing through the inside face of the knuckle when closed with coupler horn against the buffer block or end sill.

### 9.2.3 Brake Wheel Machine Vision Image Considerations

The brake wheel is identified by unfolding the image and moving the template over the image to find the best fit. If the brake wheel does not match the template it is classified as deformed. There are two primary designs of the brake wheel, dished and flat, both of which are captured in the template. The brake wheel shown in Figure 9.2 is

of the flat type. Two manufacturers of brake wheels are Cardwell Westinghouse and Ellcon-National, a subsidiary of Wabtec Company.

An alternative means of measuring brake wheel clearance should be through the use of an image that is perpendicular to the side of the train (Figure 9.5). The frame rate must be high enough to ensure that an image is captured when the brake wheel is perfectly in line with the camera target, or within a very small tolerance that would allow for accurate measurement of clearance.



**Figure 9.5 Brake wheel viewed from perpendicular to the track showing brake wheel clearance**

During much of the day the brake wheel will be in the shadow cast by an adjacent car in the train. The possibility of imaging the railcar from the side may allow the brake wheel to be more visible given the relative light from the background, but may introduce difficulties regarding dynamic backgrounds that have been encountered in other machine

vision projects (Lai et al 2004). Movement of trees, clouds, other trains, or any other objects that might be visible through the gap between two railcars can make background distinction difficult. A backdrop is one solution to this problem.

If the brake wheel is deformed, the clearance at any point in a complete rotation of the brake wheel must meet or exceed the FRA requirement. There are several approaches to determining whether or not brake wheel clearance is violated. The first of these would be through exact measurement. This is not feasible because while clearance may not be violated at the time the train passes, the brake wheel could be rotated into a position in which clearance is not met. The approach used in this research is to use template matching to flag any deformation and then allow learning to handle the categorization between FRA defects and deformation that does not constitute an FRA violation. Figure 9.6 shows a brake wheel that does not satisfy the 4” clearance requirement prescribed by CFR Part 231.



**Figure 9.6 Brake wheel with insufficient clearance per CFR Part 231**



### 9.3 Brake Step

The brake step provides a platform for a railroad employee to safely operate the handbrake. It is located immediately below the brake wheel on a railcar and extends beyond the brake wheel on either side (Figure 9.7). The platform is generally constructed of some type of grating to provide a more slip resistant surface under all conditions.



**Figure 9.7 Example images of the brake step and brake wheel**

#### *9.3.1 Brake Step Design Parameters (FRA 2004b)*

The brake step should be supported by not less than two metal braces having a minimum cross sectional area  $3/8''$  by  $1-1/2''$  or equivalent secured with no less than  $1/2''$  bolts or rivets (Figures 9.8 and 9.9).



### *9.3.2 Brake Step Dynamic Parameters (FRA 2004b)*

If a brake step is used, it should be no less than 28” in length. The outer edge of the brake step should be no more than 8” from face of car and no less than 4” from a vertical plane parallel with end of car and passing through the inside face of the knuckle when closed with coupler horn against the buffer block or end sill. Another possibility for a dynamic parameter would be securement of the brake step to the car body. It is unlikely that the brake step would not be supported by the required number of braces, but it is possible that one of the braces could become insecure.

### *9.3.3 Brake Step Machine Vision Image Considerations*

There are multiple possible views when it comes to imaging the brake step. First, if a camera were mounted perpendicular to the railcar in line with the brake step (Figure 9.10), it is possible that deformation in the vertical plane could be identified.



**Figure 9.10 Image of the brake step taken perpendicular to the tracks and in-line with the brake step**

Instead of a perpendicular view, one that is perpendicular to the tracks and above the brake step should also be considered, allowing the overall length and width of the brake step to be captured in the image (Figure 9.11). From this angle the brake step has depth and the necessary width and length parameters can be viewed allowing deformations to be identified.



**Figure 9.11 Image of the brake step taken perpendicular to the tracks and above the brake step showing the step's length**

If it is not possible to accurately identify deformations in both planes from a single view, two views will have to be used; one taken from above the railcar, and the other taken from the side. The top-down view of the brake step could provide the needed angle to monitor the necessary parameters. A top-down view would provide the

necessary angle to check the length and width of the brake step as well as brake wheel clearance. If there were a camera both above and beside the train, the two images could be compared to detect all deformation associated with the brake step.

As with the brake wheel, the area in which the brake step is located is not easily illuminated during a large portion of the day which suggests the need to use a perpendicular image. The perpendicular image is backlit and introduces potential background problems but allows the relatively dark brake step to appear distinct from the lighted background.

One of the challenges with the brake step is their range of heights on the end of the car. The brake wheel is fixed in the horizontal plane on the end of the car, but it is not fixed vertically allowing for a range in brake step locations. This does not present a problem in recognizing the brake wheel since the algorithm is written to find the circular brake wheel anywhere in the image without unfolding the image but could be a problem with the brake step.

This section does not describe end platforms, which are oftentimes referred to as crossover steps. End platforms are not required on open-top hoppers and gondolas, but when the car is equipped with an end platform it is required to be in compliance with CFR Part 231. End platforms are covered in §231.27, box and other house cars without roof hatches or placed in service after October 1, 1966. They are required to be no less than 8” in width and not less than 60” in length. They should be secured with no less than 3 metal braces at a height of no more than 8” above the top of center sill. An example of an end platform with significant deformation can be seen in Figure 9.12.



**Figure 9.12 End platform on a boxcar showing significant deformation**

#### **9.4 Sill Steps**

The sill steps provide a location from which a transportation employee can mount a car on any of the four sides. Sill steps are the location where the employee's feet often rest while they hold on to the car's handholds during movement of the railcar. Examples of sill step designs are shown in Figures 9.13 and 9.14



**Figure 9.13 Sill step without additional rung**



**Figure 9.14 Sill step with additional rung**

*9.4.1 Sill Step Design Parameters (FRA 2004b)*

Sill steps should have a cross-sectional area  $\frac{1}{2}$ " by 1-1/2", or the equivalent area, of wrought iron or steel (Figure 9.15). The minimum length of tread is 10", preferably 12". One sill step should be located on each end of the car. Sill steps must be securely fastened with no less than  $\frac{1}{2}$ " bolts with nuts (on the outside when possible) and riveted over with no less than  $\frac{1}{2}$ " rivets.

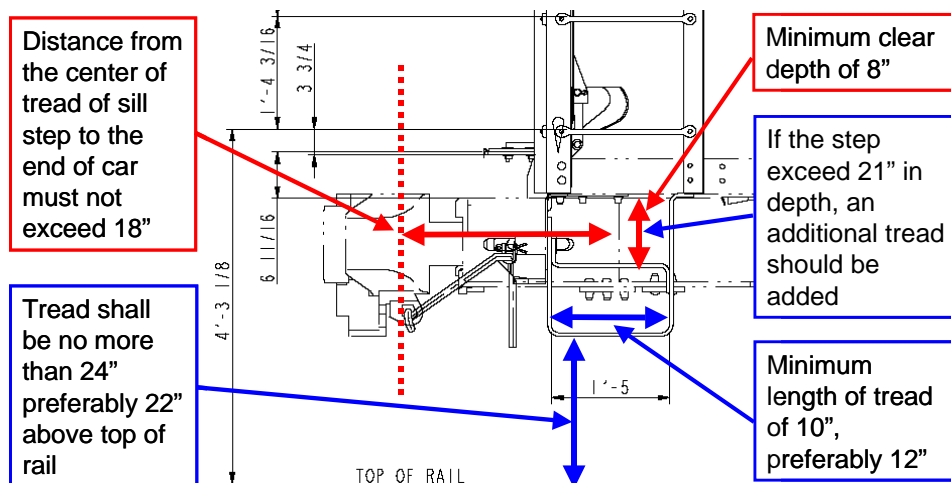

**Figure 9.15 Sill step parameters**

#### *9.4.2 Sill Step Dynamic Parameters (FRA 2004b)*

The maximum clear depth of the sill step is 8". The distance between the center of the sill step and the end of car should be no more than 18". The outside edge of the sill step tread shall be no more than 4" inside the face of the car, preferably flush with the edge of the car. The tread shall be no more than 24" above the top of the rail, preferably no more than 22". Sill steps with a depth (vertical height) greater than 21" must have an additional tread (Figures 9.14, 9.15).

#### *9.4.3 Sill Step Machine Vision Image Considerations*

Sill steps are one of the most challenging safety appliances to identify defects using machine vision. This challenge results from the shape, location, and background behind the sill steps. There are three primary designs of sill steps (Figures 9.13, 9.14, 9.16) with many subcategories due to differing means of attachment. Occasionally, these designs are changed to allow the sill step to be offset underneath the car (Figure 9.16).



**Figure 9.16 Sill step offset underneath the railcar**



This poses a problem for a vision system in that it is difficult to determine if a sill step is offset by design or if it is deformed. One solution to this problem is only flagging the sill step for deformation if the distance between the outside edge of the step and the edge of the car is greater than four inches. The other solution will be supplying the learning algorithm with exhaustive examples of sill steps that are offset by design as well as deformed ones that look similar to offset sill steps. The effectiveness of the algorithm at distinguishing between the two should then be evaluated.

Using the angled camera view below the top of rail that was used for the analysis of ladders, handholds, and the brake wheel is difficult because there is a great deal of clutter behind the sill step making analysis by machine vision algorithms difficult (Todorovic 2005). Clutter refers to other parts of the railcar that are not safety appliances and appear in the image behind the sill step. Clutter may consist of brake rigging, the truck, or other mechanical car components.

One view that could be effective in detecting sill step deformation is shown in Figure 9.17. This view is taken from an angle that is more acute with regard to the track (i.e. less than  $45^\circ$ ) than the images taken from the initial camera view. This would provide better definition of deformations in the plane of the side of the car body. This angle does not allow the distance between the center of the sill step and the end of the car to be viewed, but would allow for the measurement of distances between rungs as well as the distance to the top of rail – both of which are dynamic parameters that will need to be assessed.



**Figure 9.17 Sill step viewed from shallow angle to show sill step deformation**

Sill step deformation may come in many forms as shown in Figure 9.18. The image on the left shows an FRA defect whereas the image on the right shows deformation that is not an FRA defect.



**Figure 9.18 Sill step deformation showing an FRA defect (left) and significant deformation (right)**

## 9.5 Ladders

Ladders are used by employees to mount a railcar, ride a railcar, and obtain access to the roof or brake wheel of the railcar if necessary (Figure 9.19). Employees use both hands and feet when using the ladder treads. Certain lower treads of the side and end ladders are considered side and end handholds per the FRA regulations and will be identified below.

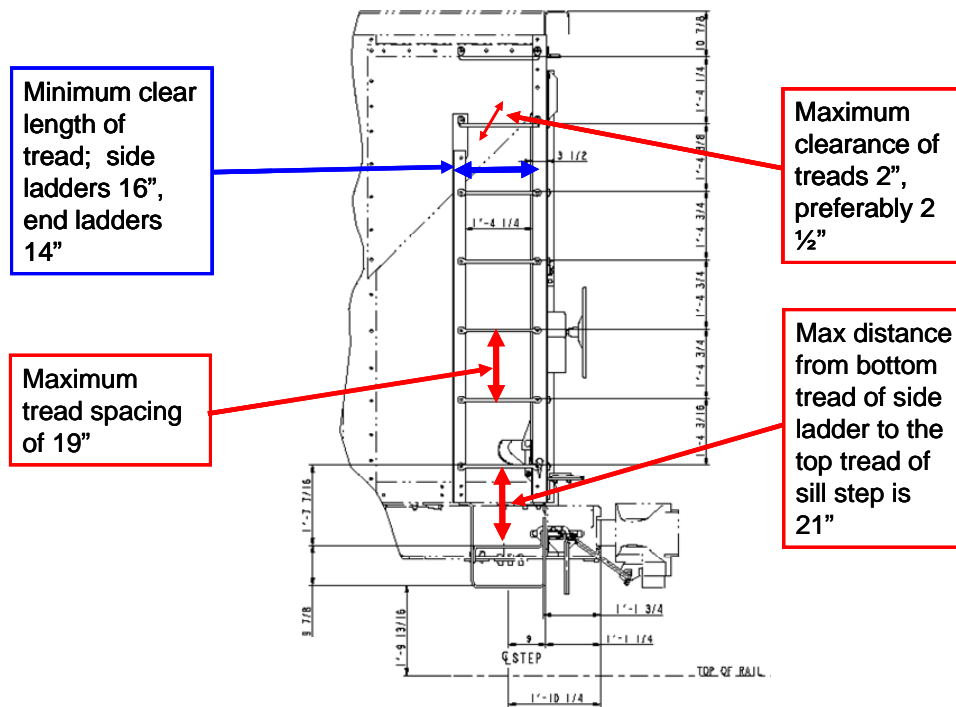

**Figure 9.19 Images of the side ladder (left) as well as an image of both the side and end ladders (right) on open-top hopper cars**

### 9.5.1 Ladder Design Parameters (FRA 2004b)

The minimum clear length of tread is 16” for side ladders, 14” for end ladders (Figures 9.20 and 9.21). The height of end ladder treads shall coincide with side ladder treads, with a variance of no more than 2” allowed. If construction does not permit the bottom treads to coincide, the bottom tread on the end ladder should coincide with the

second tread on the side ladder. Iron or steel treads must have a minimum diameter of 5/8". One ladder should be located on each side of the car. Metal ladders without stiles shall have upward projections not less than 2" in height near the inside end of bottom treads. Stiles of ladders, projecting 2" or more from the face of the car serve as foot guards. Ladders must be securely fastened with no less than 1/2" bolts with nuts (on the outside when possible) and riveted over with no less than 1/2" rivets.



**Figure 9.20 Design and dynamic parameters for ladders on an open-top hopper car**



gondolas will likely be undertaken on additional car types. Figure 9.22 shows deformation of both the side and end ladder on a covered hopper car and Figure 9.23 shows deformation of the top ladder rungs on a hopper car.



**Figure 9.22 Deformations of side and end ladders on a covered hopper car**



**Figure 9.23 Deformations of the top side ladder rung on an open-top hopper car**

## 9.6 Side Handholds

Side handholds are used for employees to hold onto the side of a railcar. The lower rungs of the side ladder on the AR and BL ends serve as the side handholds. On the AL and BR ends the side handholds are separate distinct items (Figures 9.24 and 9.25).

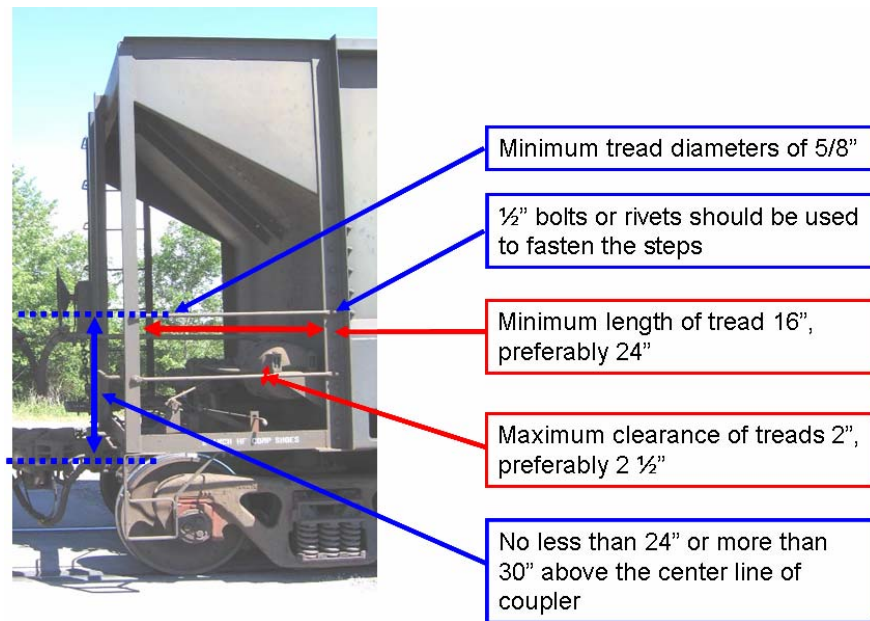

**Figure 9.24 Side handholds on both the AL and BR corners of open-top hopper cars**

### *9.6.1 Side Handhold Design Parameters (FRA 2004b)*

Four side handholds should be located on each railcar. Side handholds should be made of wrought iron or steel with a minimum diameter of 5/8". The minimum clear length should be 16", preferably 24" (Figure 9.25). One handhold should be located near each end on each side of the car. Side handholds must be securely fastened with no less

than 1/2" bolts with nuts (on the outside when possible) and riveted over with no less than 1/2" rivets.



**Figure 9.25 Design and dynamic parameters for handholds of open-top hopper cars**

### 9.6.2 Side Handhold Dynamic Parameters (FRA 2004b)

The minimum clearance should be 2", preferably 2-1/2". Side handholds should be no more than 24", nor more than 30" above the center line of coupler except when the side handhold is a ladder tread. Clearance of the outer end of handhold shall be not more than 8" from the end of the car.

### 9.6.3 Side Handhold Machine Vision Image Considerations

Side handholds are identified much the same way that ladder rungs are identified except that it may be more difficult to recognize handholds because there are fewer available for recognition. In Figure 9.26 the bolt attached to the end post of the car causes the 2" clearance parameter to be violated. Figure 9.27 shows another means by which the 2" clearance might be violated; by a piece of coal in this case. The author has



not heard of any instances in which the FRA has taken exception to clearance issues due to a commodity causing fouling the safety appliance.



**Figure 9.26 Side handhold on an open-top hopper car showing less than the required 2" clearance**



**Figure 9.27 Side handholds clearance potentially affected by a piece of coal on an open-top hopper car**

## 9.7 Horizontal End Handholds

Horizontal end handholds are used for employees to hold onto the end of a railcar while their foot rests on the sill step. As with side ladders the tread of the end ladder also serves as an end handhold, thus these can serve as a location for footing when the ladder is used.

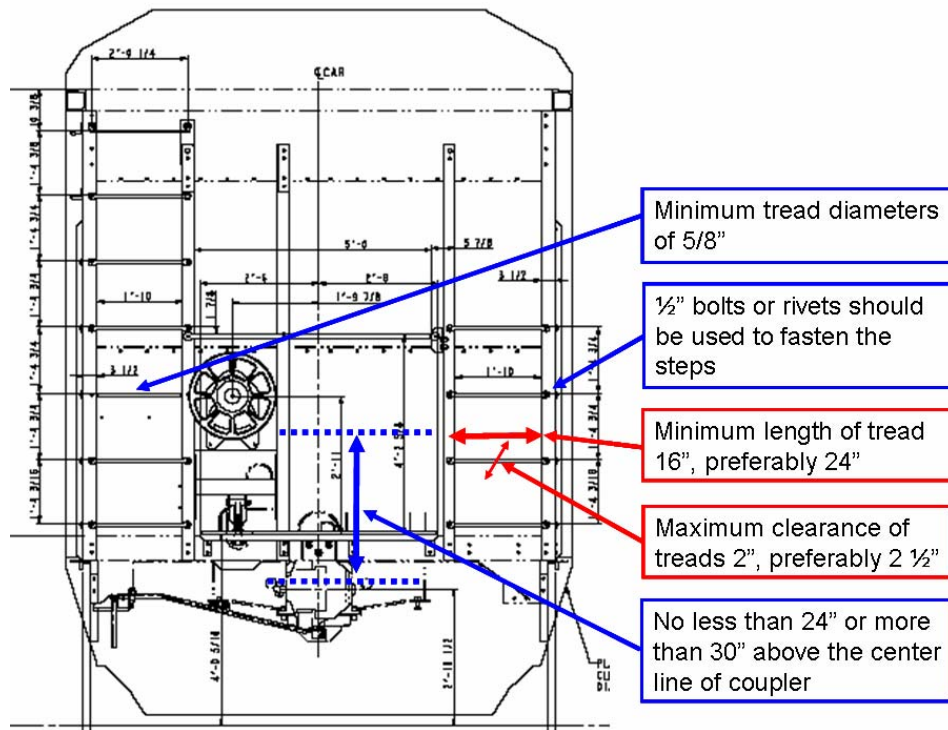

**Figure 9.28 View of both the AR and BR corners of the railcar showing the horizontal end handholds on open-top coal cars**

### *9.7.1 Horizontal End Handhold Design Parameters (FRA 2004b)*

Eight or more horizontal end handholds should be located on each railcar, with four on each end (Figures 9.29 and 9.30). Horizontal end handholds should be made of wrought iron or steel with a minimum diameter of 5/8". The minimum clear length should be 16", preferably 24". A 14" horizontal end handhold can be used if it is impossible to mount a 16" one. One handhold should be located near each side on each

end of the car. One should be located on each end of the car on the face of the end sill or sheathing over the end sill, projecting outward and down. The clearance of the outer end of horizontal end handhold should be no less than 16". On cars with end sills greater than 6" in width, there shall be one additional handhold no less than 24", located near the center of car, no less than 30" nor more than 60" above the platform end sill. Horizontal end handholds must be securely fastened with no less than 1/2" bolts with nuts (on the outside when possible) and riveted over with no less than 1/2" rivets.



**Figure 9.29 Design and dynamic parameters for horizontal end handholds**

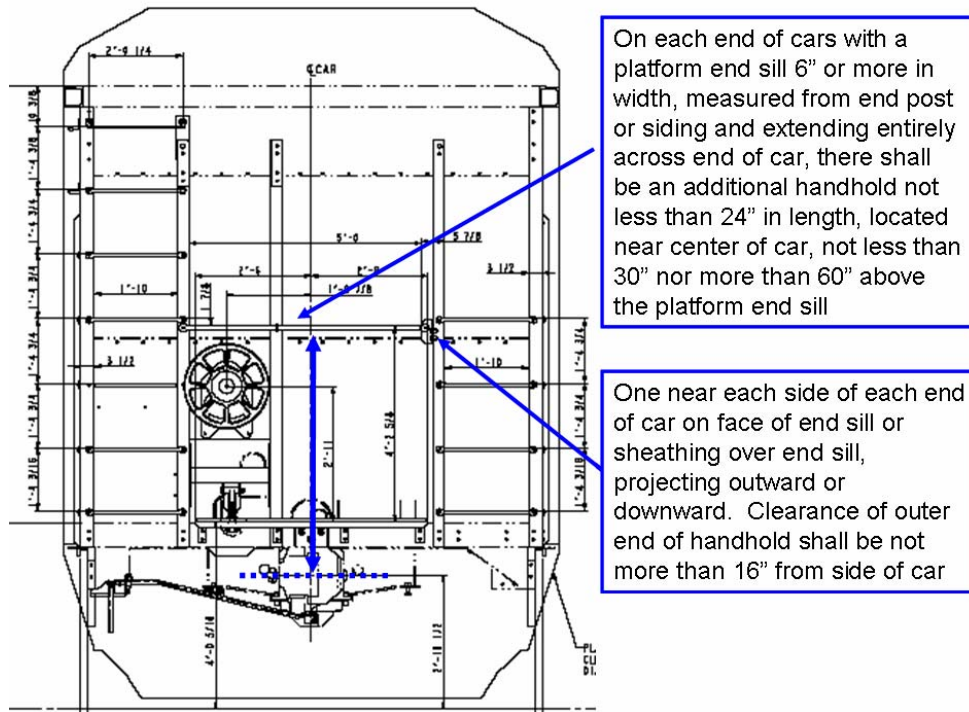

**Figure 9.30 Additional design and dynamic parameters for horizontal end handholds**

*9.7.2 Horizontal End Handhold Dynamic Parameters (FRA 2004b)*

The minimum clearance should be 2", preferably 2-1/2". Horizontal end handholds should be no more than 24", nor more than 30" above the center line of coupler except when the side handhold is a ladder tread. Clearance of outer end of handhold shall be not more than 8" from end of car.

*9.7.3 Horizontal End Handhold Machine Vision Image Considerations*

Horizontal end handholds should be easily detected through a manner that is similar to the one that recognizes ladder rung and side handholds.

## **9.8 Vertical End Handholds**

Vertical end handholds are used for employees to hold the end of a railcar that has a full width platform, most notably on boxcars.

### *9.8.1 Vertical End Handhold Design Parameters (FRA 2004b)*

Two vertical end handholds should be located on each full width platform end-sill car. Vertical end handholds should be made of wrought iron or steel with a minimum diameter of 5/8". The minimum clear length should be 18", preferably 24". Vertical end handholds should be located opposite of the ladder, no more than 8" from the side of the car. Vertical end handholds should be no more than 24", or more than 30" above the centerline of coupler. Vertical end handholds must be securely fastened with no less than 1/2" bolts with nuts (on the outside when possible) and riveted over with no less than 1/2" rivets.

### *9.8.2 Vertical End Handhold Dynamic Parameters (FRA 2004b)*

The minimum clearance should be 2", preferably 2-1/2".

### *9.8.3 Vertical End Handhold Machine Vision Image Considerations*

The identification of vertical end handholds would require an approach different than the ones used to identify ladder rungs and handholds due to the vertical alignment of the handhold. Another difficulty may arise from the lack of multiple rungs to ease the task of locating rungs as periodically spaced parallel lines.

## 9.9 Uncoupling Levers

Uncoupling levers are used by railroad employees to uncouple two railcars. Employees actuate these while they are standing or walking alongside the railcar while the train is in motion to uncouple railcars from one another.

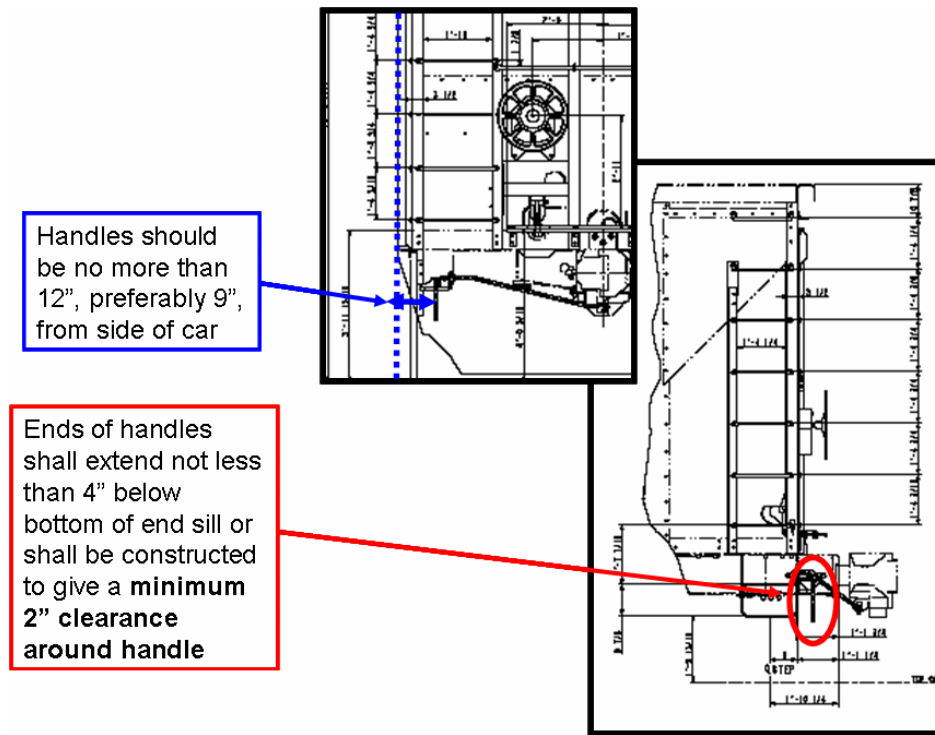

**Figure 9.31 Example of an uncoupling lever**

### *9.9.1 Uncoupling Lever Design Parameters (FRA 2004b)*

Two uncoupling levers should be located on each car using any efficient design. If the car does not comply with plate B, handles should be no more than 6” from the side of the car (Figure 9.32). If the car does comply with plate B, the handle should be no more than 12”, preferably 9” from the side of car with a center lift arm no more than 7” long. The center of eye at the end of lift arm shall not be more than 3-1/2” beyond the center of eye of uncoupling pin of coupler. The minimum drop of the handle should be 12” and the maximum drop should be no more than 15” overall. Handles of the “rocking” or “pushdown” variety shall not be more than 18” from the top of rail when the

cock has released the knuckle, and a suitable stop shall be provided to prevent the inside arm from flying up in case of breakage.



**Figure 9.32 design and dynamic parameters for the uncoupling lever**

### *9.9.2 Uncoupling Lever Dynamic Parameters (FRA 2004b)*

The minimum clearance around the handle should be 2" and handles should extend no more than 4" below the bottom of end sill.

### *9.9.3 Uncoupling Lever Machine Vision Image Considerations*

The uncoupling lever may prove to be the most challenging of all safety appliances to identify using machine vision. The primary parameter that can be identified using machine vision is the clearance around the lever. The primary difficulty in identifying the uncoupling lever is the amount of "clutter" in the background which produces many more edges than the uncoupling lever. Additionally, there is no angle

from which the uncoupling lever can be viewed that allows it to appear parallel or perpendicular to any reference point in the image. Another difficulty in recognizing the uncoupling lever is the wide variety of uncoupling lever designs. While all of these uncoupling lever designs conform to CFR Part 231 the slight differences provide challenges to a machine vision system.

## **9.10 End Ladder Clearance**

End ladder clearance ensures that there is clearance for a railroad employee to safely use the end ladder, brake step, or end platform without risk of coming in contact with an adjacent railcar.

### *9.10.1 End Ladder Clearance Design Parameters (FRA 2004b)*

The car is designed in a manner such that no portion of the car should be within 30” from the end of the car other than those specified (Figure 9.33). To be conservative, these parameters will be considered dynamic parameters and will be addressed in the following section.

### *9.10.2 End Ladder Clearance Dynamic Parameters (FRA 2004b)*

No part of the car above end sills should be within 30” from the side of car except for the buffer block, brake shaft, brake wheel, or uncoupling lever shall extend to within 12” of a vertical plane parallel with the end of the car and passing through the inside face of the coupler when closed.



No part of car above the end sills shall be within 30" from side of car, except for the buffer block, brake shaft, brake wheel, brake step and uncoupling lever shall extend to within 12" of a plane extending through the end of the car (knuckle definition)

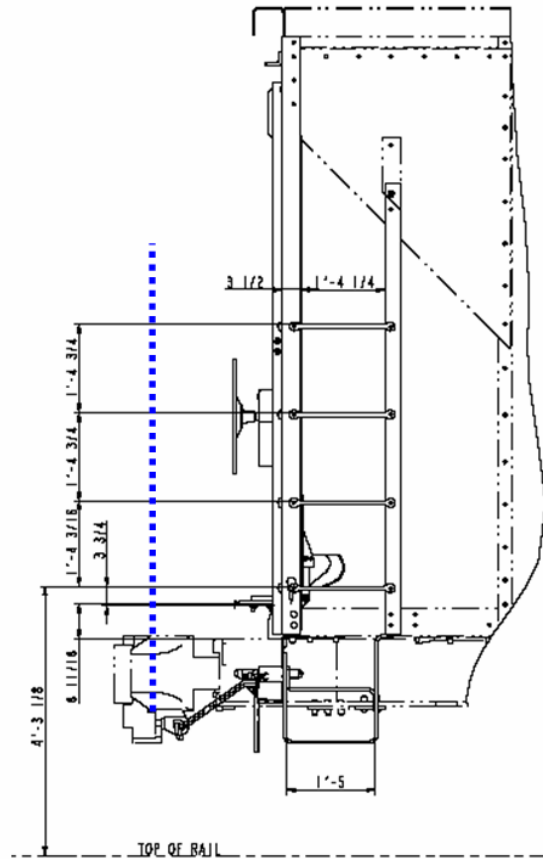

**Figure 9.33 Design and dynamic parameters for end ladder clearance**

*9.10.3 End Ladder Clearance Machine Vision Image Considerations*

End ladder clearance can be determined by a view that is perpendicular to the tracks. This view must be captured with a frame rate that allows the end of the car to be inline with the camera allowing for an accurate measurement of the distance between the end of the car and the knuckle.

## **CHAPTER 10: CONCLUSION**

### **10.1 Summary**

Since the installation of safety appliances was first required on railcars in 1893, they have been visually inspected by humans. However, humans are limited in their ability to rapidly and objectively assess many different items for extended periods and avoid succumbing to fatigue. Railroad car inspections require railroad carmen to inspect as many as 1,000 cars per shift, making the task monotonous and leaving room for error. Technologies and inspection methods should be investigated that will increase both the effectiveness and efficiency of safety appliance inspections. The positive effects of adding additional technology to the car inspection process was shown through the qualitative inspection cost model in Chapter 5.

The use of a machine-vision-enhanced inspection process could improve performance and speed while possibly reducing cost. The capital cost of a machine vision system will be higher than incremental addition to the labor force; however, the cost per unit inspected may be lower, depending on the number of cars to be inspected at a particular location. Additionally, the system would enable reallocation of labor to tasks for which they are uniquely qualified, such as railcar repair. To take further advantage of the system, some type of system memory should be incorporated because it would enable better planning of railcar maintenance.

There are many examples of wayside rail vehicle health monitoring systems that have been installed or are in the research and development stages. Examples of wayside

vehicle health monitoring systems are WILDs, TPDs, and the FactIS system which were discussed in Chapter 6. These and other technologies can be linked to the InteRRIS database which provides centralized information to the railroads and car owners allowing for better management of railcar repair.

An additional benefit of a machine-vision-enhanced inspection system is that it has the potential to partially alleviate congestion in rail yards. Because much of the inspection process will occur along the line of road or at the entrance to a yard, railcars may not need to occupy yard trackage for as long while they await and undergo inspection. Instead, based on the outcome of the machine-vision results certain cars requiring a closer look or minor repair could be promptly inspected and repaired, while the remainder could be shunted directly to either their appropriate outbound track, or to a major repair track. In conclusion, the prototype systems described here have the potential to improve rail transportation safety and efficiency in several ways, including improving the efficiency and effectiveness of the inspection process as well as improving rail yard safety and productivity.

## **10.2 Future Research and Issues**

Some repair issues may arise regarding how a defective safety appliance is dealt with if it is detected between terminals where a repair shop is not located. This issue will need to be addressed between the AAR and FRA before a machine vision system is placed in the field with the capability of inspecting safety appliances.

As machine vision detection of safety appliances is adapted to other car and appliance types, there are underlying difficulties that must be addressed. Some of these

issues are lighting needed for a machine vision system, the need to ensure safety appliances are securely fastened, as well as how to store data on safety appliance defects.

Additional research should be undertaken to determine the magnitude of the added capacity on receiving and departure tracks if additional technologies are added that will increase the efficiency and effectiveness of car inspections. An economic analysis of additional yard capacity gained from wayside inspection would aid in determining if such an inspection system is cost justified.

There are a few modifications to the FRA database and data acquisition process that would be helpful for future research. One modification would be the requirement for inspectors to fill out narratives even if there is no fatality to allow for greater use of the FRA database. Another suggestion would be the addition of codes that would point to whether or not an accident or injury was caused by a defective safety appliance allowing for better quantification of injuries associated with defective safety appliances.

## REFERENCES

- Adome (2006). Lens and Field of View Calculator.  
[http://www.adome.net/catalog/information.php/info\\_id/10](http://www.adome.net/catalog/information.php/info_id/10). [April 18, 2006].
- Aldrich, M. (1992) Safety First Comes to the Railroads, 1910-1939. *Railroad History*, Vol. 166, Spring 1992, pp 7-33.
- Aldrich, M. (1997). *Safety First – Technology, Labor, and Business in the Building of American Work Safety*, The Johns Hopkins University Press, Baltimore, MD, pp 1-415.
- Ameen, P. (2005-2006). Assistant Vice President, Technical Services. Association of American Railroads (AAR). Personal Communications. [December 2005 - March 2006].
- Association of American Railroads (AAR) (2003a). *Car Repair Statistical Report – 2003*, Unpublished AAR Data.
- Association of American Railroads (AAR) (2003b). *Railroad Facts - 2003 Edition*, Association of American Railroads, Washington, D.C.
- Association of American Railroads (AAR) (2004). *Field Manual of the AAR Interchange Rules*, Association of American Railroads, Washington, D.C.
- Association of American Railroads (AAR) (2005). *2004 Analysis of Class I Railroads* Association of American Railroads, Washington, D.C.
- Association of American Railroads (AAR) (2006). Data Presented at the Technology Driven Train Inspection Task Force Meeting in Washington, DC, February 7-8, 2006. Association of American Railroads, Washington, D.C.
- Batchelor, B. (2005). *Natural and Artificial Vision*,  
<http://bruce.cs.cf.ac.uk/bruce/MV%20overview/TEXT.htm>, [July 31, 2005].
- Browder, W. (2005). Director of Operations, Association of American Railroads (AAR), Personal Communication. [February 2005].
- Carrulo, S. (2005). Safety Appliances / Railway Equipment Specialist, Federal Railroad Administration (FRA). Unpublished Data, Personal Communication [June 2005].
- Cielo, P. (1998). *Optical Techniques for Industrial Inspection*. Academic Press, Inc., San Diego, CA, pp 1-606.

- Dirnberger, J. (2006). *Production Management Methods and the Development of a Quality of Sort Metric to Improve Classification Terminal Performance*. Unpublished Masters Thesis. University of Illinois at Urbana-Champaign, Urbana, Illinois.
- Federal Railroad Administration (FRA) (1981). Office of Research and Development. *Railroad Classification Yard Technology Manual Volume I: Yard Design Methods*. SRI International, Menlo Park, CA.
- Federal Railroad Administration (FRA) (2001). Office of Research and Development. *An Examination of Railroad Yard Worker Safety*. Washington, D.C., <http://www.fra.dot.gov/downloads/Research/ord0120.pdf>, [August 2005].
- Federal Railroad Administration (FRA) (2004a). Office of Safety. *Motive Power and Equipment Compliance Manual*, Chapter 10: Railroad Safety Appliance Standards. Washington, D.C., <http://www.fra.dot.gov/us/content/1248>, [February 2004].
- Federal Railroad Administration (FRA) (2004b). Office of Safety. Title 49 Code of Federal Regulations (CFR), *Railroad Mechanical Department Regulations, CFR Parts 210, 215, 216, 217, 218, 221, 223, 225, 229, 231, and 232*. Railway Educational Bureau, Omaha, NE. [February 15, 2004].
- Federal Railroad Administration (FRA) (2005). Office of Safety. *Query Page*. <http://safetydata.fra.dot.gov/OfficeofSafety/Query/Rrsys.pdf>. [July 31, 2005].
- Feigenbaum, A.V. (1983). *Total Quality Control*, McGraw Hill, New York, NY, pp 122-124.
- Hart, J. M., Ahuja, N., Barkan, C.P.L., & Davis, D.D. (2004). *A Machine Vision System for Monitoring Railcar Health*, Technology Digest, TD-008-2004, Association of American Railroads, Washington, D.C.
- Hart, J. M. (2004-2006). Research Engineer, University of Illinois Urbana-Champaign. Personal Communications [August 2004 - March 2006].
- Hoyt, D. (2004). United States Region Mechanical Officer, Canadian National Railway. Personal Communication. [November 18, 2004].
- Interstate Commerce Commission (ICC) (1893). *Seventh Annual Report of the Interstate Commerce Commission*, GPO, Washington D.C, 1893, pp 1-285.
- Interstate Commerce Commission (ICC) (1909). *Twenty-Third Annual Report of the Interstate Commerce Commission*, GPO, Washington D.C, 1909, pp 1-338.

- Interstate Commerce Commission (ICC) (1910). *Twenty-Fourth Annual Report of the Interstate Commerce Commission*. GPO, Washington, D.C. 1910. pp 1-358.
- Kennedy, C. W. & Andrews, D. E. (1977). *Inspection and Gaging*. Industrial Press, Inc., New York, NY, pp 1-598.
- Lai, Y.C., Hart, J. M., Vemuru, P., Drapa, J., Ahuja, N., Barkan, C., Milhon, L., & Stehly, M., (2005). Machine Vision Analysis of the Energy Efficiency of Intermodal Trains. In *Proceedings of the 8th International Heavy Haul Conference "Safety, Environment, Productivity"*, (Cristiano G. Jorge, Coordinator - Technical Committee), Rio de Janeiro, Brazil, June 14-16, 2005, International Heavy Haul Association, Virginia Beach, VA, pp. 387-394.
- Luczak, M., (2005), Going by the Wayside, *Railway Age*, January 2005, [http://findarticles.com/p/articles/mi\\_m1215/is\\_1\\_206/ai\\_n11835921](http://findarticles.com/p/articles/mi_m1215/is_1_206/ai_n11835921), [August 2005].
- Medico-Actuarial Mortality Investigation (1913). *The Effect of Occupation on Mortality*. The Association of Life Insurance Medical Directors and The Actuarial Society of America, New York, NY, pp. 16-19.
- Morgan, R. & Anderson, G., (2003). TTCI Plays Detective: Transportation Technology Center Inc.'s Intergraded Railway Remote Information Service, *Railway Age*, [http://www.findarticles.com/p/articles/mi\\_m1215/is\\_2\\_204/ai\\_98265137](http://www.findarticles.com/p/articles/mi_m1215/is_2_204/ai_98265137), [August 2005].
- Official Railway Equipment Register (ORER). (2005). The, R.E.R. Publishing Corporation, New Jersey, Vol. 120, No. 3, p HC-15-16.
- Railway Educational Bureau (1998). *Inbound Car Inspection Program*, Training Technologies, Omaha, NE.
- Shapiro, L.G. & Stockman, G.C. (2001). *Computer Vision*, Prentice Hall, Upper Saddle River, NJ, pp 1-50.
- Smith, M. (2004-2006). Senior Mechanical Supervisor Central Illinois, Canadian National Railway. Personal Communications. [November 18, 2004 – March 2006].
- Switching Operations Fatality Analysis (SOFA) (2004). *Findings and Recommendations of the SOFA Working Group*, August 2004 Update. <http://www.fra.dot.gov/us/content/1506>. [September 20, 2005].
- Todorovic, S. (2005-2006). Postdoctoral Assistant, University of Illinois Computer Vision and Robotics Laboratory. Personal Communications [May 2005 - March 2006].

United States House of Representatives (U.S. House) (2004). Office of Law Revision Council. Chapter 203: Safety Appliances, Safety Appliance Statute, <http://uscode.house.gov/>, [April 1, 2006].

Wetzel, K. W. (1977). *The Impact of Federal Safety Appliance Legislation Upon Railroad Accidents*. Doctoral Thesis. University of Illinois at Urbana-Champaign, Urbana, IL, pp 144-167.

White, J.H. (1993). *The American Railroad Freight Car*. The Johns Hopkins University Press, Baltimore, MD, pp 517-518.

White, J.H. (2005). The Strongest Handshake in the World. *Invention and Technology*, Winter 2005, pp 51-54.



## **APPENDICES**

### **APPENDIX A – Inbound Car Inspection Priorities**

Training Technologies, Inc. summarizes the defects that should be recognized as the following:

1. Open missing or defective doors or door hangers (Non-SA)
2. Hand brake and hand brake chain defects that prevent proper hand brake operation such as components that are not intact, bent, broken, or ineffective
3. A minimum clearance of 4 inches between the hand brake wheel and car body
4. Ladders, including ladder treads, that are bent or broken
5. A minimum clearance of 2 inches between the ladder treads and the car body
6. A minimum clearance of 2 inches or more around the uncoupling handle
7. Uncoupling handle to be 12 to 15 inches in length
8. Bent or broken uncoupling levers that prevent uncoupling mechanism to operate
9. Uncoupling levers on cars with cushioning devices that fail to telescope
10. Brake stapes that are damaged, loose, or not in place
11. Brake steps to be at least eight inches wide and the front of the step to be at least four inches from the inside face of the coupler
12. Crossover steps to be at least 60 inches long
13. Sill steps to be securely fastened and to have adequate clearance
14. Sill steps to be less than 21 inches between treads
15. Safety railings on tank cars to be securely fastened and run the full length of the tank, with proper clearance